

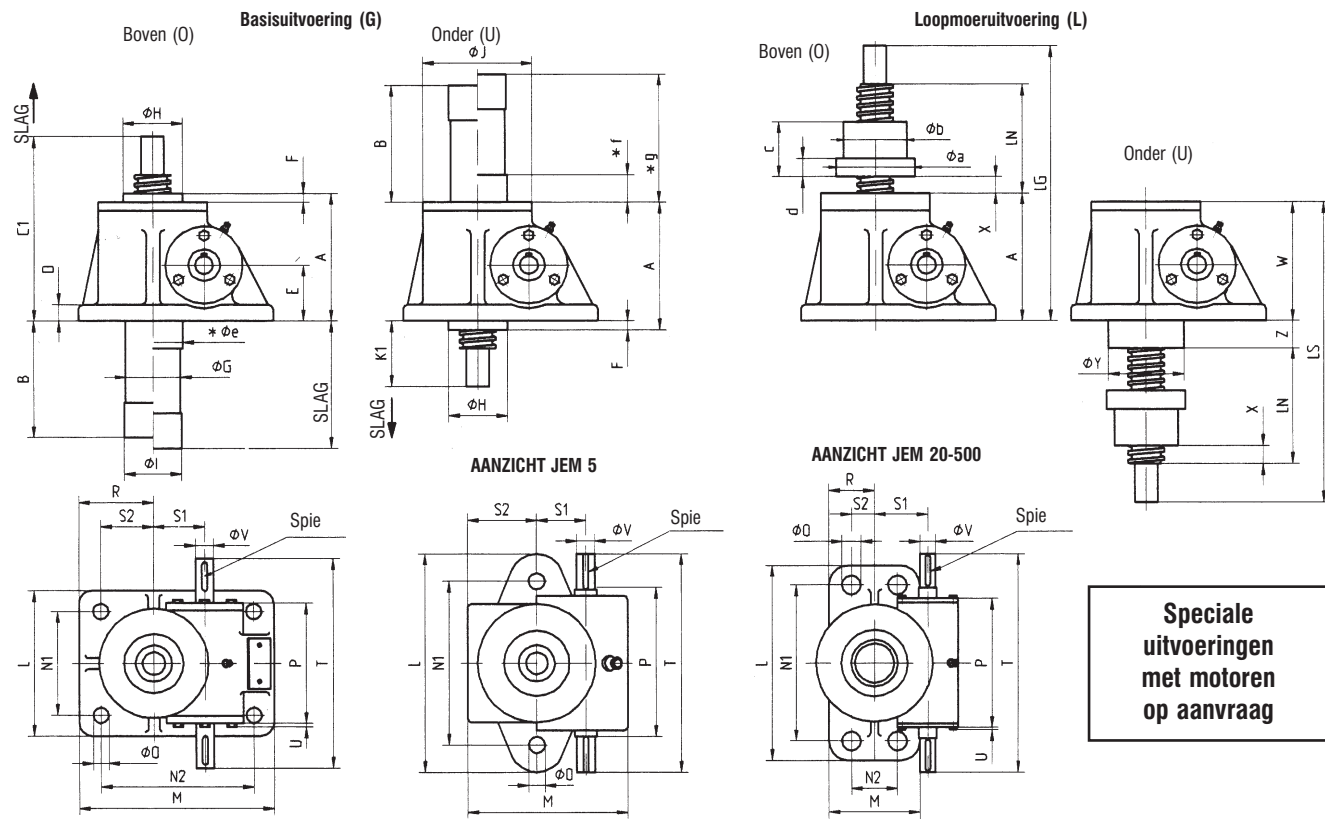

**MAATTABEL JEM - SCHROEFSPINDELAANDRIJINGEN**



Type	JEM5	JEM15	JEM20	JEM30	JEM50	JEM100	JEM150	JEM200	JEM240	JEM300	JEM350	JEM500	JEM1000
Spindel	Tr20x6	Tr24x6	Tr26x6	Tr30x6	Tr40x9	Tr55x12	Tr60x12	Tr65x12	Tr75x14	Tr90x16	Tr100x16	Tr120x16	
A	74	90	104	105	140	150	160	187	210	222	255	275	
B	Slag+15	Slag+20	Slag+25	Slag+25	Slag+25	Slag+25	Slag+25	Slag+25	Slag+25	Slag+25	Slag+25	-	
C1	106	130	156	157	202	215	235	274	300	312	355	455	
D	10	12	15	12	18	20	20	25	25	25	30	35	
E	32	36	44	45	61,5	66	70	87	95	102	115	130	
F	5	10	10	10	10	10	10	10	10	10	15	15	
Ø G	28	38	45	45	60	70	76	82	102	115	132	140	
Ø H	36	40	48	48	65	78	82	100	110	130	150	170	
Ø I	30	40	48	48	63	73	79	85	105	118	139	144	
Ø J	65	82	98	98	120	138	150	185	192	205	260	300	
K1	37	50	62	62	72	75	85	97	100	100	115	195	
L	120	100	185	120	160	190	205	220	240	265	280	500	
M	88	135	95	165	214	225	237	297	320	355	430	260	
N1	90	75	152	90	114	140	155	160	180	190	210	400	
N2	-	110	57	135	168	180	190	240	260	280	360	150	
Ø O	9	9,5	11	14	17	18	21	28	28	35	35	48	
P	76	86	100	110	132	158	172	213	215	221	265	330	
R	-	50	47,5	65	82	83	88	124	120	133	170	130	
S1	27	36	45,2	45,2	56,2	63	66,8	72,5	80	97	120	137	
S2	38	37,5	28,5	50	58	60	63,5	95	90	95	135	75	
T	120	150	180	180	230	250	280	325	340	355	430	560	
U	-	6	6	6	6	7	7	7	7	7	10	10	
Ø V	10k6	14k6	14k6	16k6	20k6	24k6	25k6	28k6	32k6	34k6	38k6	40k6	
Spie	3x3x22	5x5x22	5x5x28	5x5x28	6x6x32	8x7x40	8x7x45	8x7x45	10x8x50	10x8x50	10x8x50	12x8x80	
W	69	80	94	95	130	140	150	177	200	212	240	260	
X**	10	20	20	20	20	20	25	25	25	25	25	50	
Ø Y	45	48	60	60	83	95	110	140	150	160	170	210	
Z	18	20	24	24	30	32	34	39	45	52	52	29	
LN	Slag+52	Slag+75	Slag+80	Slag+80	Slag+100	Slag+110	Slag+125	Slag+150	Slag+160	Slag+170	Slag+195	Slag+255	
LG	Slag+148	Slag+185	Slag+216	Slag+217	Slag+282	Slag+305	Slag+335	Slag+399	Slag+435	Slag+457	Slag+525	Slag+660	
LS	Slag+161	Slag+195	Slag+230	Slag+231	Slag+302	Slag+327	Slag+359	Slag+428	Slag+470	Slag+499	Slag+562	Slag+674	
Im	Ø a	50	60	76	76	87	98	110	120	130	155	225	
	Ø b	40	40	50	50	70	75	90	90	100	130	160	
	c	32	35	40	40	60	70	75	100	110	120	145	155
	d	10	15	20	20	20	25	25	30	30	35	50	
gr*	Ø e	36	40	48	48	65	78	82	100	110	130	170	
	e	16	24	24	30	30	30	26	35	40	45	10	
	g	Slag+32	Slag+38	Slag+40	Slag+40	Slag+43	Slag+42	Slag+42	Slag+55	Slag+40	Slag+40	Slag+60	Slag+25

\* Maten voor 2e geleidering (gr) met bescherm pijp (t.b.v. geringe zijkrachten) - \*\* Veiligheid - Im = Loopmoer

**SPINDELEINDEN**

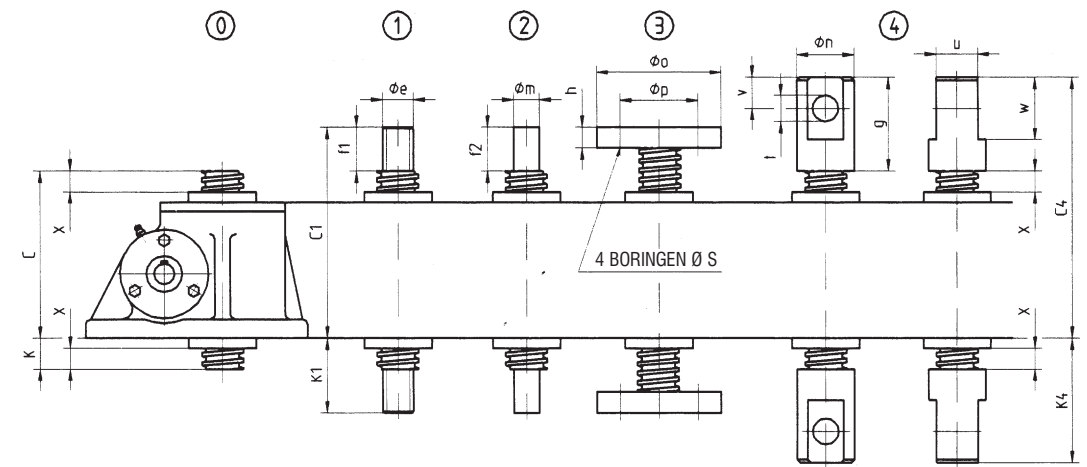

Type	JEM5	JEM15	JEM20	JEM30	JEM50	JEM100	JEM150	JEM200	JEM240	JEM300	JEM350	JEM500	JEM1000
0	C	84	110	124	125	160	170	185	212	235	247	280	325
	K	15	30	30	30	30	30	35	35	35	40	65	
1	Ø e	M12	M16	M18x1,5	M20x1,5	M30x2	M36x3	M40x3	M50x3	M55x3	M70x3	M80x3	M100x5
	f1	22	20	32	32	42	45	50	62	65	65	75	130
2	Ø m	12	17	18(17)	20	25	35	40	50	55	70	80	100
	f2	22	20	32	32	42	45	50	62	65	65	75	130
3	h	12	15	18	18	20	25	25	30	30	40	55	55
	Ø o	65	82	98	98	120	138	150	185	185	205	260	300
	Ø p	45	65	75	75	75	100	105	140	140	155	200	225
	Ø s	7	9	10,5	10,5	17	18	21	26	26	27	33	35
4	g	50	50	65	65	90	100	120	130	140	155	175	250
	Ø n	30	35	40	40	55	65	80	85	95	108	120	148
	t	15	15	15	15	25	30	35	40	45	50	60	65
	u	20	25	30	30	40	50	60	65	75	80	100	120
v	15	15	23	23	30	30	45	50	50	60	65	85	
w	30	35	46	46	60	70	90	100	110	120	130	170	
C4	134	160	189	190	250	270	305	342	365	402	455	575	
K4	65	80	95	95	120	130	155	165	175	190	215	315	

Afwijkende uitvoeringen op aanvraag

**ZWENKELEMENT (JES)**

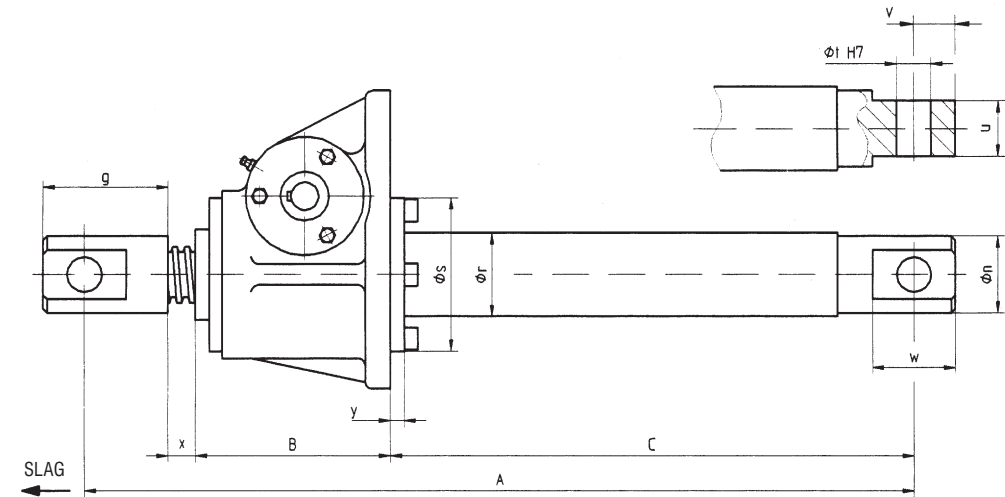

Type	JES5	JES15	JES20	JES30	JES50	JES100	JES150	JES200	JES240	JES300	JES500
A	Slag+180	Slag+215	Slag+247	Slag+250	Slag+320	Slag+330	Slag+390	Slag+432	Slag+475	Slag+502	Slag+762
B	74	90	103	106	140	150	160	187	210	222	282
C	Slag+61	Slag+75	Slag+82	Slag+82	Slag+100	Slag+110	Slag+130	Slag+140	Slag+150	Slag+160	Slag+265
g	50	50	65	65	90	100	120	130	140	155	250
Ø n	30	35	40	40	55	65	80	85	95	108	148
Ø r	28	36	45	45	60	70	80	90	110	127	150
Ø s	59	65	80	80	110	120	140	160	180	190	240
Ø t H7	15	15	15	15	25	30	35	40	45	50	65
u	20	25	30	30	40	50	60	65	75	80	120
v	15	15	23	23	30	40	45	50	50	60	85
w	30	35	46	46	60	80	90	100	110	120	170
x	10	20	20	20	20	20	25	25	25	25	50
y	8	10	10	10	10	12	15	20	20	20	25

Afwijkende uitvoeringen op aanvraag