

Falk™ Steelflex® Grid Couplings | Redefining Total Coupling Value
(English-Metric)

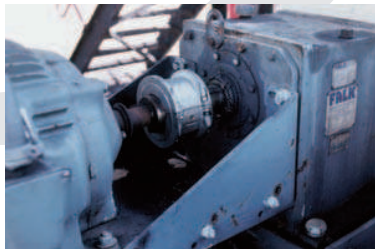
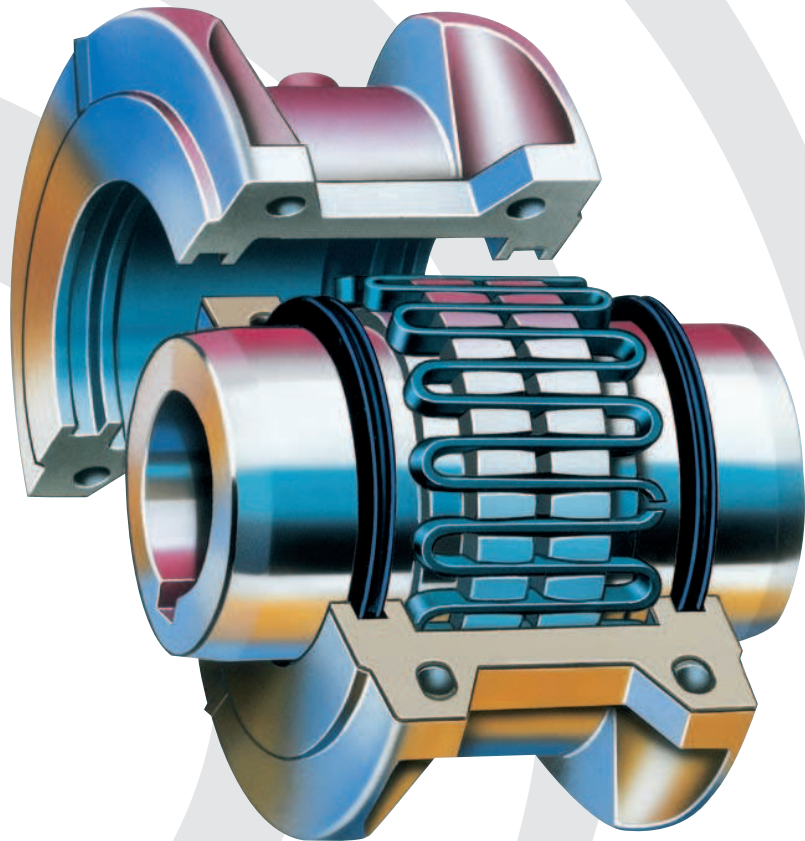

REXNORD

Falk™ Steelflex®

The simplest, most cost-effective coupling

The Falk name is synonymous with grid couplings, as well as using shot peening to increase fatigue strength and torque ratings.

Steelflex redefines total coupling value up to 7.5 million in-lb, 932 000 Nm torque. Steelflex offers simpler initial installation than gear couplings, and our new HD design outlasts competitive gear couplings 2 to 1.

The unique “replace in place” design eliminates the need to move hubs or re-align shafts, reducing element change-out time.

When you look (see chart below) at the overall savings in initial costs, spare parts costs, and labor costs for installation, alignment and replacement - plus improved ratings and a 5 Year Heavy-Duty Warranty - it's easy to see what Steelflex Grid Couplings have over the competition. No other coupling in the torque range can touch Steelflex for cost-effective performance and reliability.

Features That Give Steelflex the Lowest Lifetime Operating Cost

Longer Life

Tapered grids, made of high strength alloy steel, are quenched and tempered to spring hardness. The grid surface is then precision shot peened to compress the surface molecules.

The effect is a dramatic increase in rating, providing reserve strength for longer life or allowing a smaller size coupling to be selected.

This precision technology was originally used in the production of sophisticated aircraft components.

Extended Maintenance Periods

Now you can install Steelflex and lubricate it with Falk Long Term Grease (LTG) and forget periodic, routine maintenance for five years.

Falk LTG grease was developed specifically for couplings. It resists the separation of the oil and thickening agent that occurs in typical greases.

The initial use of Falk LTG coupling grease will eliminate routine lubrication cycles while still providing the necessary lubrication to the tapered grid.

With LTG, Steelflex combines the high torque performance of a gear coupling and the low maintenance of a disc or elastomer coupling.

Type HD Couplings

The Preferred Replacement for Gear Couplings

- Durable Nitrile Seals are heat resistant to 275° F. (135° C.)
- Powder-coated covers provide chemical resistance.

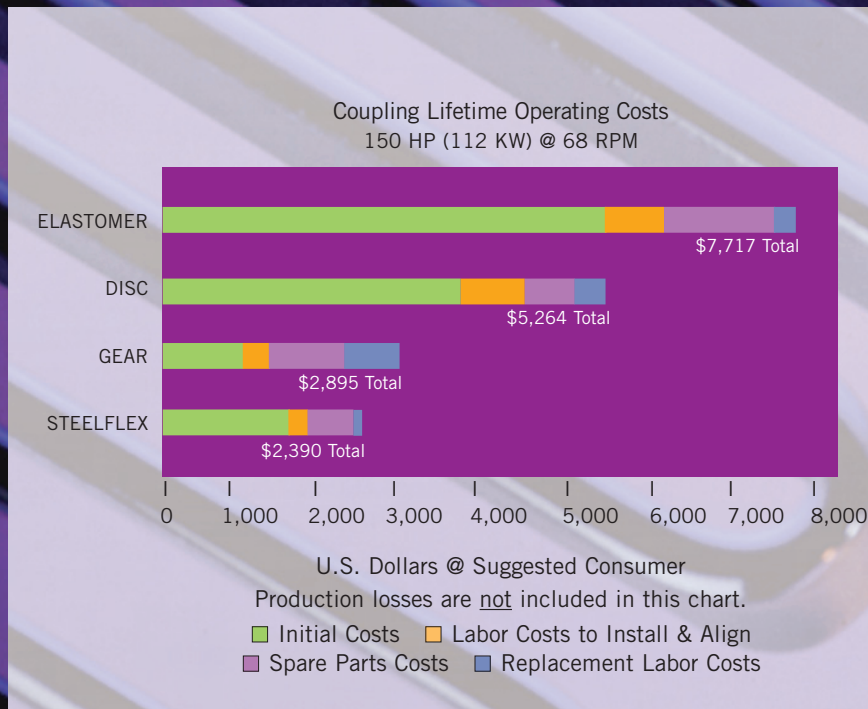

**Quick, Easy Installation...
Replace-In-Place Design**

The grid is the wearing member of a Steelflex coupling and it is a fraction of the complete coupling cost. Tapered grids are accessible through the quickly removable cover.

The replace-in-place design of the replacement grids allows them to be dropped in without the need to remove or reposition hubs or realign shafts as required with gear couplings and many elastomer designs

When coupling-connected equipment must be moved, the job takes longer and costs a lot more.

Equipment Protection Against Shaft Misalignment

The grid is free to rock, pivot and float within the hub teeth. Generous misalignment capacity is provided without producing detrimental bearing side loads created by other couplings.

Equipment Protection Against Shock/Vibratory Loads

Torsional flexibility is the ability of Falk Steelflex couplings to torsionally deflect when subjected to normal shock or vibratory loads, providing flexible accommodation to changing load conditions.

Consequently, Steelflex tunes the drive system. It absorbs impact energy by spreading it over an increment of time. It damps vibration and reduces peak or shock loads by as much as 30%. It is a true shock absorber for rotary motion, relying on the predictable resilience of the steel grid for torsional flexibility.



**Steelflex HD Grid Couplings –
The preferred replacement for
gear couplings**

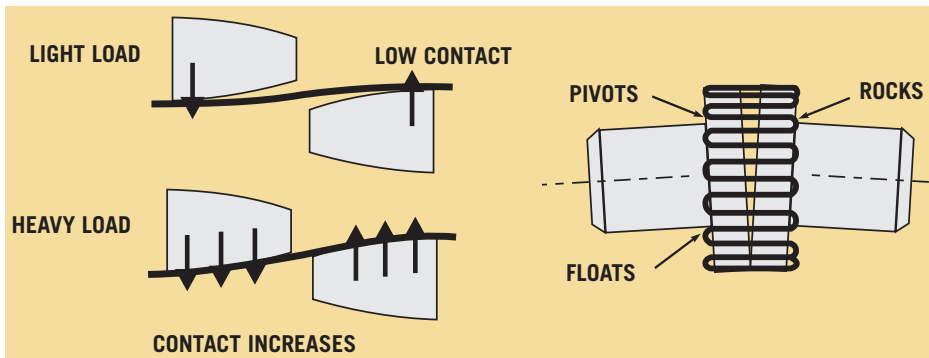

Versatile Designs

Two cover designs are available in the popular sizes. Standard spacer, piloted, high speed, brakewheel or disc, and controlled torque designs are also available.

Worldwide Availability

Steelflex couplings and component parts, are available in popular sizes and types. Our distribution centers and worldwide distribution network offer the largest stock of rough bore, finish straight bore and Taper-lock bushed hubs of any shaft coupling on the market. Plus, Steelflex grid couplings are warranted for 5 Years when lubricated with Falk LTG Long Term Grease.

Steelflex Selection Guide

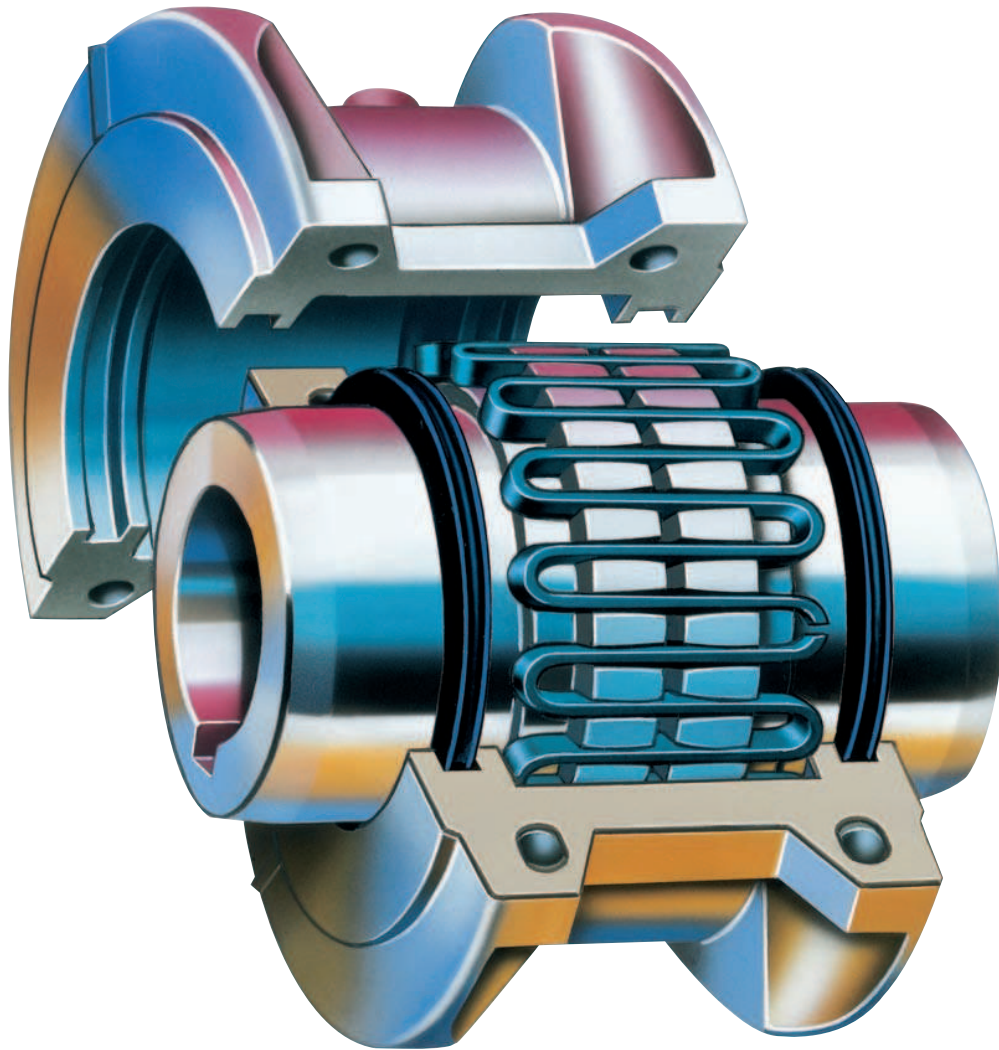

Selection Guide M421-110, February 2007

Table of Contents

How to Select, Standard & Formula Methods	7-9
Quick selection Method	10-11
Service Factors	12
How to Order	13
T Type Steelflex Grid Couplings:	
Dimensions & Specifications	
Type T10 Close Coupled	14
Type T20 Close Coupled	15
Type T31 Full Spacer	16-17
Type T35 Half Spacer	18-19
Type T41 & LT Controlled Torque Coupling	20
Type T44 Controlled Torque Clutches	21
Type T45 & T42 Piloted Controlled Torque Assemblies	22
Optional Automatic Proximity Sensor Cutout Switch	23
Slip Torque Performance Charts	24-27
Type T50 Floating Shaft Assembly	28
Type T50 Floating Shaft Selections	29
Type T63 Disc Brake	30-32
Type T70 High Speed	33
Type T90 Flywheel	34
Type T10/G82 Spacer	35
Engineering Data	
Recommended Commercial Keys – Metric and Inch	36
Shaft Diameters & Ratings for 50 Hertz Metric Motors & NEMA 60 Hertz	36
Bore Ranges With Square & Rectangular Keys	37-38
Taper Lock Bushings for Type T Hubs & Shaft Hubs	39
WR ² Values	40
Misalignment Capacities	40
Standard AISE AC & DC Mill Motor Coupling Selections	41
Taper and Counter Bore Limitations	42
Puller Bolt Holes	42
Recommended Bores – Metric and Inch	43-45
Coupling Application Data Sheet	46



Factory Warranty We're so confident in the performance and reliability of our latest generation of Falk gear drives that we're backing this comprehensive offering with the best standard warranty in the business. Our full, 3-year Heavy-Duty Warranty provides "shaft-to-shaft" protection on all Falk components – including bearings and seals. It's an industry first... and one more powerful reason why Rexnord is your ultimate bottom-line drive and coupling value.★ Steelflex grid couplings are warranted for 5 years when lubricated with Falk LTG Long Term Grease.

★ Warranty extends for 3 years from date of shipment.

Copyright 2003, 2007. Rexnord Industries, LLC. All Rights Reserved. Litho in U.S.A.
Steelflex and Rexnord are registered trademarks of Rexnord Industries, LLC. Falk is a trademark of Rexnord. Dodge is a registered trademark. Taper-Lock is a registered trademark of a bushing under license.

The contents of this selection guide are subject to change without notice or obligation.
Information contained herein should be confirmed before placing orders.

All Falk Steelflex® Couplings Possess the Following Benefits

- High Ratings
- Extended Maintenance Periods
- Quick Installation
- Easy Maintenance
- Versatile Design
- Availability
- Protection Against Shaft Misalignment
- Protection Against Shock Loads, Vibration and Thrust Loads

General Information

- Rexnord standards apply unless otherwise specified.
- All Dimensions are for reference only and are subject to change without notice unless certified.
- Unless otherwise specified, Falk coupling hubs Sizes 1020T thru 1090T will be bored for CLEARANCE FIT with a setscrew OVER the keyway, and Sizes 1100T and larger will be furnished for INTERFERENCE FIT without a setscrew (see Table 27, Page 43). Recommended key sizes for the listed maximum bores are shown in Table 13 on Page 36.
- Torque ratings of couplings utilizing Taper-Lock bushings can differ from those that do not. Refer to the Factory for details.
- If Rexnord is to supply coupling hubs bored for Taper-Lock bushings, the bushing manufacturer MUST be noted on the order.
- Consult the Factory when limited end float is required.

Reference Notes

- † Peak torque capacity is two times the published rating. Torque ratings for hubs with bushings differ from those shown, refer to Table 19, Page 39.
- ‡ Consult the Factory for higher speeds.
- Maximum bores are reduced for hubs furnished with an INTERFERENCE FIT and a setscrew OVER the keyway. Refer to Rexnord Engineering Sheet 427-105 for details.
- Minimum bore is the smallest bore to which a RSB hub (rough stock bore) hub can be bored. Depending upon coupling size, rough stock bore hubs may have only a blind centering hole or a through hole that will permit remachining of the hubs to the minimum bores specified.

Falk Steelflex Grid Couplings

A general purpose, lubricated design that combines the economy and high torque capacity of a gear coupling with the torsional flexibility of an elastomer coupling. Backed by a 5-year lubrication warranty, Falk Steelflex couplings require no periodic maintenance when lubricated with Falk LTG (Long Term Grease) at installation. Featuring 25 sizes, Steelflex couplings can accommodate torque loads of 932 000 (Nm) and shaft diameters of 508 millimeters.

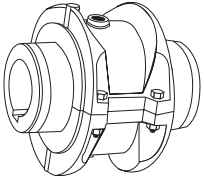

A double flexing, close-coupled design for use in four bearing systems. Features a horizontally split cover which allows for grid replacement without the movement of the connected equipment. (See Page 14.)

Type T10 Close Coupled

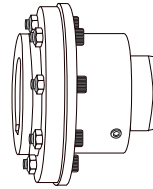

For use on line shaft applications. Can be used in place of single engagement gear couplings to provide torsional resiliency and lower overall operating cost. (See Pages 28 & 29.)

Type T50 Piloted

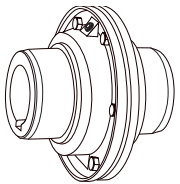

A double flexing design featuring a vertically split steel cover. Ideal for higher running speeds. (See Page 15.)

Type T20 Close Coupled

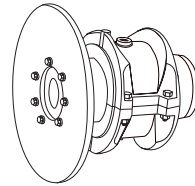

Proven to be far superior to drum-type brakes in cost, construction and performance. (See Pages 30 thru 32.)

Type T63 Disc Brake

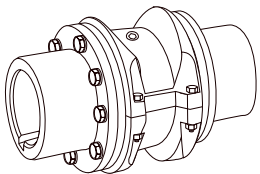

Complete center section drops out for easy service of connected equipment bearings and seals. Ideal for pump applications. (See Pages 16 & 17.)

Type T31 Full Spacer

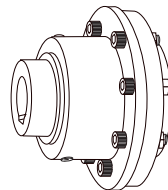

Designed for operating speeds beyond those of the T10 and T20 designs. Features a one-piece cover and balanced components. (See Page 33.)

Type T70 High Speed

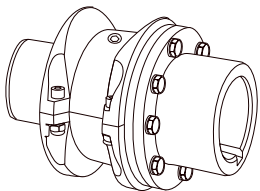

An economical spacer design for easy service of connected equipment bearings and seals. Ideal for pump applications. (See Pages 18 & 19.)

Type T35 Half Spacer

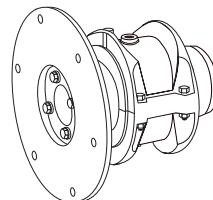

Used primarily to connect the flywheel of an engine to the driven machinery. It provides for higher torque ratings with resulting smaller sizes and lower costs than elastomer couplings. (See Page 34.)

Type T90 Flywheel

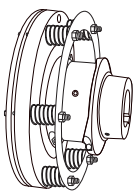

Provides adjustable slipping action to protect connected equipment from shock, jams, or temporary overloads. (See Pages 20 thru 27.)

Type T41, T42, T44 & T45 Controlled Torque

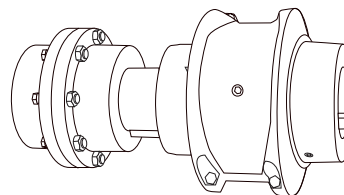

A combination of two standard Falk couplings. Utilizes readily available components for an economical price and shorter lead time than T31/T35 couplings. (See Page 35.)

Type T10/G82 Spacer



Double piloted design for connecting equipment where the distance between shafts is too large for a spacer type coupling. (See Pages 28 & 29.)

Type T50 Floating Shaft

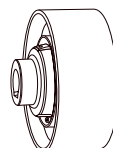

Provides a built-in braking surface right at or near the centerline of the coupling . . . saves space and dollars. (See Selection Guide 431-310.)

Type BW Brakewheel

WARNING! Mixing grid coupling components from different manufacturers may cause premature failure and possible personal injury or property damage from flying debris.

How to Select

Standard Selection Method (except T41/T44 & T63)

The standard selection method can be used for most motor, turbine, or engine driven applications. The following information is required to select a flexible coupling:

- Kilowatt (kW) or torque
- Running rpm
- Application or type of equipment to be connected (motor to pump, gear drive to conveyor, etc.)
- Shaft diameters
- Shaft gaps
- Physical space limitations
- Special bore or finish information and type of fit

Exceptions are High Peak Loads and Brake Applications. For these conditions use the Formula Selection Method in the next column, or consult your local Falk Representative for assistance.

1. **RATING:** Determine system torque. If torque is not given, calculate as shown below:

$$\text{System Torque (Nm)} = \frac{\text{kW} \times 9549}{\text{rpm}}$$

Where kilowatt (kW) is the actual or transmitted power required by the application (if unknown, use the motor or turbine nameplate rating) and rpm is the actual speed the coupling is rotating. Applications that require rapid changes in direction or torque reversals should be referred to Rexnord Engineering.

2. **SERVICE FACTOR:** Determine appropriate service factor from Table 4, Page 12.
3. **REQUIRED MINIMUM COUPLING RATING:** Determine the required minimum coupling rating as shown below:
Minimum Coupling Rating = S.F. (Service Factor) x Torque (Nm)
4. **TYPE:** Refer to Page 6 and select the appropriate coupling type.
5. **SIZE:** Turn to appropriate pages for the coupling type chosen and trace down the torque column to a value that is equal or greater than that determined in Step 3 above. The coupling size is shown in the first column.
6. **CHECK:** Check speed (rpm), bore, gap, and dimensions.

STANDARD SELECTION EXAMPLE:

Select a coupling to connect a 55 kW, 1500 rpm electric motor driving a lobe type blower. Motor shaft diameter is 60 mm, blower shaft diameter is 45 mm. Shaft extensions are 140 mm and 110 mm. Selection is replacing a gear type coupling with a 3 mm gap.

1. **DETERMINE REQUIRED RATING:**

$$\text{System Torque (Nm)} = \frac{55 \text{ kW} \times 9549}{1500 \text{ rpm}} = 350 \text{ Nm}$$

2. **SERVICE FACTOR:** From Table 4 = 1.25
3. **REQUIRED MINIMUM COUPLING RATING:**
 $1.25 \times 350 \text{ Nm} = 438 \text{ Nm}$
4. **SIZE:** From Page 14 a Size 1070T is the proper selection based on a torque rating of 904 Nm exceeding the required minimum coupling rating of 438 Nm.
5. **CHECK:** Allowable speed capacity of 4125 (1070T10) exceeds the required speed of 1500 rpm. Maximum bore capacity of 67 mm exceeds the actual shaft diameters.

Type T63 Static (holding) Brake Applications

1. **SIZE:** The brake rating must equal or exceed the application requirements. Determine the required coupling size by comparing the application loads (from Steps A and B below) to the coupling brake rating listed on Page 31. Use the highest torque value calculated to determine the coupling size.

- A. For normal service applications, use the application torque in Nm.

$$\text{System Torque (Nm)} = \frac{\text{Transmitted kW} \times 9549}{\text{rpm}}$$

- B. For repetitive high peak load applications, use the system peak torque in Nm. (Repetitive is defined as more than 1000 times during the expected coupling life.)

2. **CALIPER TORQUE BRAKE RATING:** For the coupling size selected, compare the caliper brake torque rating on Page 31 to the holding torque requirement of the application. Rexnord recommends that the caliper torque rating (min.) be at least two times the holding torque requirement for static applications to compensate for the possibility of foreign matter on the disc surfaces, loss of condition of the brake pad surfaces, or other conditions that may affect the holding ability of the caliper brake.

Caliper brakes and brake discs listed are designed primarily for static and/or emergency brake applications. **NOTE:** Check brake system and lining wear after emergency stops. They can, however, also be used for dynamic stopping if only used occasionally, such as shutting down the equipment for the day or between shift changes. For stopping high inertia systems or for applications that require more frequent stopping, consult your local Rexnord Representative.

3. **CHECK:** Check maximum bores, speeds, and dimensions.

Type T63 Stopping Or Service Brake Applications

1. **SIZE:** The coupling brake rating must equal or exceed the application requirements. Determine the required coupling size by comparing the application loads (from Steps A, B and C below) to the coupling brake rating listed on Page 28. Use the highest torque value calculated to determine the coupling size.

- A. For the selected caliper brake and disc diameter, use the maximum brake torque in Nm.
- B. For normal service applications, use the application torque in Nm.

$$\text{System Torque (Nm)} = \frac{\text{Transmitted kW} \times 9549}{\text{rpm}}$$

- C. For repetitive high peak load applications, use the system peak torque in Nm (Repetitive is defined as more than 1000 times during the expected coupling life.)

2. **CHECK:** Check maximum bores, speeds, and dimensions.

How to Select

Formula Selection Method (except T41/T44 & T63)

The Standard Selection Method can be used for most coupling selections. The procedures below should be used for:

- High Peak Loads.
- Brake Applications (where the brake disc or brake wheel is to be an integral part of the coupling, consult the Factory for design options).

Providing system peak torque and frequency, duty cycle, and brake torque rating will allow for a more refined selection using the Formula Selection Method.

- HIGH PEAK LOADS:** Use one of the following formulas for applications using motors with torque characteristics that are higher than normal; applications with intermittent operations, shock loading, inertia effects due to starting and stopping and or system induced repetitive high peak torques. System Peak Torque is the maximum torque that can exist in the system. Select a coupling with a torque rating equal to or greater than selection torque calculated below.

A. NON-REVERSING HIGH PEAK TORQUE

Selection Torque (Nm) = System Peak Torque
or

$$\text{Selection Torque (Nm)} = \frac{\text{System Peak kW} \times 9549}{\text{rpm}}$$

B. REVERSING HIGH PEAK TORQUE

Selection Torque (Nm) = 2 x System Peak Torque
or

$$\text{Selection Torque (Nm)} = \frac{2 \times \text{Peak kW} \times 9549}{\text{rpm}}$$

- OCCASIONAL PEAK TORQUES (Non-Reversing)** If a system peak torque occurs less than 1000 times during the expected coupling life, use the following formula:

Selection Torque (Nm) = 0,5 x System Peak Torque
or

$$\text{Selection Torque (Nm)} = \frac{0,5 \times \text{Peak kW} \times 9549}{\text{rpm}}$$

For reversing service select per step B.

- BRAKE APPLICATIONS:** If the torque rating of the brake exceeds the motor torque use the brake rating as follows:

Selection Torque (Nm) = Brake Torque Rating x S.F.

FORMULA SELECTION EXAMPLE — High Peak Load:

Select a coupling for reversing service to connect a gear drive low speed shaft to a runout mill table roll. The electric motor rating is 37 kW at the base speed and the system peak torque at the coupling is estimated to be 17 000 Nm. Coupling speed is 77 rpm at the motor base speed. The drive shaft diameter is 100 mm with a key of 28 mm x 16 mm. The runout table roll diameter is 135 mm with a key of 36 mm x 20 mm. Maximum shaft gap (BE) is 180 mm long.

- TYPE:** Refer to Page 6 and select the appropriate coupling type.

2. REQUIRED MINIMUM COUPLING RATING:

Use the Reversing High Peak Torque formula in Step 1B.

$$2 \times 17\,000 = 34\,000 = \text{Selection Torque}$$

- SIZE:** From Page 19, Size 1150T35 with a torque rating of 39 800 exceeds the selection torque of 34 000 Nm.

- CHECK:** The 1150T35 has a maximum BE dimension of 187,5 mm; the shaft hub has a maximum bore of 270 mm (Table 16, Page 37); the T hub has a maximum bore of 215 mm (Table 15, Page 37); and the allowable speed of 1500 rpm and the dimensions on Page 19 meet the requirements.

TABLE 1 — Coupling Ratings & Allowable Speeds

Coupling Size ★	kW/RPM ♦	Torque Rating (Nm) †	Allowable Speeds —rpm ‡			
			T10	T20 & T50 *	T31, T35 & T10/G82	T70
1020T	0,005	52	4500	6000	3600	...
1030T	0,016	149	4500	6000	3600	10000
1040T	0,026	249	4500	6000	3600	...
1050T	0,046	435	4500	6000	3600	9000
1060T	0,072	684	4350	6000	3600	...
1070T	0,104	994	4125	5500	3600	8200
1080T	0,215	2 050	3600	4750	3600	7100
1090T	0,39	3 730	3600	4000	3600	6000
1100T	0,657	6 280	2440	3250	2440	4900
1110T	0,976	9 320	2250	3000	2250	4500
1120T	1,43	13 700	2025	2700	2025	4000
1130T	2,08	19 900	1800	2400	1800	3600
1140T	2,99	28 600	1650	2200	1650	3300
1150T	4,16	39 800	1500	2000	1500	...
1160T	5,86	55 900	1350	1750	1350	...
1170T	7,81	74 600	1225	1600	1225	...
1180T	10,8	103 000	1100	1400	1100	...
1190T	14,3	137 000	1050	1300	1050	...
1200T	19,5	186 000	900	1200	900	...
1210T	26	249 000	820
1220T	35,1	336 000	730
1230T	45,6	435 000	680
1240T	58,6	559 000	630
1250T	78,1	746 000	580
1260T	97,6	932 000	540

★ Refer to Page 5 for General Information and Reference notes.

♦ kW/RPM and torque rating values for hubs with Taper Lock ® bushings differ from those shown above. Refer to Table 19, Page 39.

* Speeds shown above are for single Type T50 couplings; speeds for Type T50 Floating Shaft couplings are shown in Table 12, Page 29.

How to Select

Type T41 Controlled Torque Couplings & T44 Controlled Torque Clutches

Type T41 Controlled Torque Couplings

1. **RUNNING TORQUE:** Calculate normal running torque

$$\text{Running Torque (Nm)} = \frac{\text{Required kW} \times 9549}{\text{rpm}}$$

2. **SLIP TORQUE:** Slip torque = Running Torque x 150% (Overload Setting.) Rexnord recommends a minimum 150% overload setting for steady or moderate shock load applications. For heavy shock load applications, a 200% or greater overload setting may be required.
3. **COUPLING SIZE:** Refer to Table 8, Page 20 — Trace down the Slip Torque column to a figure equal to or in excess of the calculated slip torque determined in Step 2. Read the coupling size in the next column.

4. **CHECK:**

- A. Check shaft diameters against coupling maximum bores shown in Table 8, Page 20. If selection does not have adequate bore capacity, refer to Table 15, Page 37 or Table 17, Page 38 for maximum bores with square or rectangular keys, or select the next larger size coupling.
- B. Check the required speed against the allowable speed shown in Table 8, Page 20. If a higher speed is required, refer application details to the local Rexnord representative.
- C. Check allowable slip torque times from Slip Torque Performance Charts on Pages 24 through 27. The length of time a coupling can slip without exceeding its thermal capacity is a function of the slip torque setting and the operating speed. An automatic cutout switch, Page 23, can be provided when damaging thermal conditions exist.
- D. Check application dimension requirements against selected coupling dimensions shown on Page 20.
- E. Check usable shaft length to the coupling hub lengths on Page 18. If necessary, overhang hubs within the limits specified on Page 23.

SELECTION EXAMPLE:

Select a controlled torque coupling to connect a 15,0 kW, 1500 rpm, 160L frame motor to the high speed shaft of a gear drive driving a screw feeder. Motor shaft diameter is 42 mm with a usable shaft length of 110 mm. Drive high speed shaft diameter is 35 mm with usable shaft length of 65 mm.

1. **RUNNING TORQUE:** From Step 1 above:

$$\text{Running Torque (Nm)} = \frac{15,0 \text{ kW} \times 9549}{1500 \text{ RPM}} = 95,5 \text{ Nm}$$

2. **SLIP TORQUE:** From Step 2 above: Slip Torque = 95,5 Nm x 150% = 143,2 Nm.
3. **SIZE:** From Table 8, Page 20, the minimum size coupling is the Size 40T41, which has a maximum slip torque of 167 Nm.

4. **CHECK:**

- A. From Table 8, Page 20, the Size 40T41, T41 hub has a maximum bore capacity of only 35 mm and the T hub maximum bore capacity is 43 mm. The preferred mounting arrangement is to have the T41 hub on the motor (for optimum cooling during slippage). Therefore, select the size 50T41 with a T41 hub maximum bore capacity of 45 mm, as compared to the motor shaft diameter of 42mm, and the slip torque required is within its range.
- B. Allowable Speed of 3600 rpm exceeds required 1500 rpm.
- C. From Page 24, the Size 50T41 with slip torque setting of 143,2 Nm and running speed of 1500 rpm will permit 27 seconds slip if followed by 9 minutes of non-slip.
- D. See Page 20 for dimensions.
- E. Usable shaft length of motor is 110 mm and "W" dimension for T41 hub is 87,4 mm, therefore no overhang required. Usable shaft length of drive is 65 mm and "C" dimension of "T" hub is 60,5 mm, therefore no overhang required.

Type T44 Controlled Torque Clutches

1. **RUNNING TORQUE**

$$\text{Running Torque (Nm)} = \frac{\text{Required kW} \times 9549}{\text{rpm}}$$

2. **SLIP TORQUE:** Slip Torque = Running Torque x 150% (Overload Setting.) Rexnord recommends a minimum 150% overload setting for steady or moderate shock load applications. For heavy shock load applications a 200% or greater overload setting may be required.
3. **CLUTCH SIZE:** Refer to Table 9, Page 21 — Trace down the Slip Torque column to a figure equal to or in excess of the calculated slip torque determined in Step 2. Read clutch size in the next column.
- A. Check shaft diameters against clutch maximum bores shown in Table 9. If selection does not have adequate bore capacity refer to Table 17, Page 38 for maximum bores with square or rectangular keys, or select the next larger size clutch.
- B. Check the required speed against the allowable speed shown in Table 9. If a higher speed is required, refer application details to the local Rexnord representative.
- C. Check allowable slip torque times from Slip Torque Performance Charts on Pages 24 through 27. The length of time a clutch can slip without exceeding its thermal capacity is a function of the slip torque setting and the operating speed. An automatic cutout switch, Page 23, can be provided when damaging thermal conditions exist.
- D. Check application dimension requirements against selected clutch dimensions shown on Page 21.
- E. Check usable shaft length to the clutch hub length on Page 19. If necessary, overhang hub within the limits specified on Page 23.

Quick Selection Method

1. Select Coupling Type

Refer to Page 6 and select the type of coupling to suit your application. If an application requires a special purpose coupling, refer application details to the local Rexnord Representative.

2. Determine Service Factor.

A. For MOTOR, TURBINE or ENGINE driven applications, refer to Tables 4 and 5.

B. For BRAKE or HIGH PEAK LOAD applications, refer to the Formula Selection Method shown on Page 8.

3. Determine Equivalent Power.

Refer to Table 4 — Under the actual kW required and opposite the service factor determined in Step 2, read the equivalent kW.

4. Determine Coupling Size.

A. Refer to Table 4 — Trace horizontally from the required speed to a hp value equal to or larger than the equivalent kilowatts determined in Step 3. Read the coupling size at top of column.

TABLE 2 — Equivalent Power = (Actual kW x Service Factor)

Service Factor ‡	Actual kW																														
	0.25	0.37	0.55	0.75	1.1	1.5	2.2	3	4	5.5	7.5	9.2	11	15	18.5	22	30	37	45	55	75	90	110	132	150	185	200	220	250	300	330
1.00	0.25	0.37	0.55	0.75	1.1	1.5	2.2	3	4	5.5	7.5	9.2	11	15	18.5	22	30	37	45	55	75	90	110	132	150	185	200	220	250	300	330
1.25	0.31	0.46	0.69	0.9	1.4	1.9	2.8	3.8	5	6.9	9.4	11.5	13.8	18.8	23.1	27.5	37.5	46.3	56.3	68.8	93.8	113	138	165	188	231	250	275	313	375	413
1.50	0.38	0.56	0.83	1.1	1.7	2.3	3.3	4.5	6.0	8.3	11.3	13.8	16.5	22.5	27.8	33.0	45.0	55.5	67.5	82.5	113	135	165	198	225	278	300	330	375	450	495
1.75	0.44	0.65	0.96	1.3	1.9	2.6	3.9	5.3	7.0	9.6	13.1	16.1	19.3	26.3	32.4	38.5	52.5	64.8	78.8	96.3	131	158	193	231	263	324	350	385	438	525	578
2.00	0.50	0.74	1.1	1.5	2.2	3.0	4.4	6.0	8.0	11.0	15.0	18.4	22.0	30.0	37.0	44.0	60.0	74.0	90.0	110	150	180	220	264	300	370	400	440	500	600	660
2.50	0.63	0.93	1.4	1.9	2.8	3.8	5.5	7.5	10	13.8	18.8	23.0	27.5	37.5	46.3	55.0	75.0	92.5	113	138	188	225	275	330	375	463	500	550	625	750	825
3.00	0.75	1.1	1.7	2.3	3.3	4.5	6.6	9.0	12	16.5	22.5	27.6	33.0	45.0	55.5	66.0	90.0	111	135	165	225	270	330	396	450	555	600	660	750	900	990
3.50	0.88	1.3	1.9	2.6	3.9	5.3	7.7	10.5	14	19.3	26.3	32.2	38.5	52.5	64.8	77.0	105	130	158	193	263	315	385	462	525	648	700	770	875	1050	1155

‡ For service factors not listed. Equivalent kW = Actual kW x Service Factor.

TABLE 3 — Coupling Selection . . . Based on Equivalent kW Ratings

	1020T	1030T	1040T	1050T	1060T	1070T	1080T	1090T	1000T	1100T	1120T	1130T
Max Bore (mm)	28	35	43	50	56	67	80	95	110	120	140	170
Max Speed T10	4500 rpm	4500 rpm	4500 rpm	4500 rpm	4350 rpm	4125 rpm	3600 rpm	3600 rpm	2440 rpm	2250 rpm	2025 rpm	1800 rpm
Max Speed T20	6000 rpm	6000 rpm	6000 rpm	6000 rpm	6000 rpm	5500 rpm	4750 rpm	4000 rpm	3250 rpm	3000 rpm	2700 rpm	2400 rpm
Torque (Nm)	52	149	249	435	685	995	2050	3730	6275	9320	13670	19885
kW / rpm	0,005	0,016	0,026	0,046	0,072	0,104	0,215	0,39	0,657	0,976	1,43	2,08
RPM	kW Ratings											
4500	24.5	70.2	117	205	322	469	966					
3600	19.6	56.2	94	164	258	375	773	1410				
3000	16.3	46.8	78	137	215	313	644	1170	2370			
2500	13.6	39.0	65.2	114	179	260	537	977	1650	2930	4290	
2100	11.4	32.8	54.8	96	150	219	451	820	1380	2050	3010	5210
1800	9.8	28.1	46.9	82	129	188	386	703	1180	1760	2580	3750
1750	9.5	27.3	45.6	80	125	182	376	684	1150	1710	2510	3640
1450	7.9	22.6	37.8	66.1	104	151	311	566	954	1420	2080	3020
1170	6.4	18.3	30.5	53.3	84	122	251	457	770	1140	1670	2440
1000	5.4	15.6	26.1	45.6	72	104	215	391	658	976	1430	2080
870	4.7	13.6	22.7	39.6	62.3	91	187	340	572	849	1250	1810
720	3.9	11.2	18.8	32.8	51.6	75	155	281	474	703	1030	1500
650	3.5	10.1	16.9	29.6	46.5	67.7	140	254	428	634	931	1350
580	3.2	9.1	15.1	26.4	41.5	60.4	125	227	382	566	830	1210
520	2.8	8.1	13.6	23.7	37.2	54.2	112	203	342	508	744	1080
420	2.3	6.6	11.0	19.1	30.1	43.8	90	164	276	410	601	875
350	1.9	5.5	9.1	15.9	25.1	36.5	75	137	230	342	501	729
280	1.5	4.4	7.3	12.8	20.0	29.2	60.1	109	184	273	401	583
230	1.3	3.6	6.0	10.5	16.5	24.0	49.4	90	151	224	329	479
190	1.0	3.0	5.0	8.7	13.6	19.8	40.8	74.2	125	185	272	396
155	0.8	2.4	4.0	7.1	11.1	16.2	33.3	60.5	102	151	222	323
125	0.68	2.0	3.3	5.7	9.0	13.0	26.8	48.8	82	122	179	260
100	0.54	1.6	2.6	4.6	7.2	10.4	21.5	39.1	65.8	98	143	208
84	0.46	1.3	2.2	3.8	6.0	8.8	18.0	32.8	55.3	82	120	175
68	0.37	1.06	1.8	3.1	4.9	7.1	14.6	26.6	44.7	66.4	97	142
56	0.30	0.87	1.5	2.6	4.0	5.8	12.0	21.9	36.8	54.7	80	117
45	0.25	0.70	1.2	2.0	3.2	4.7	9.7	17.6	29.6	43.9	64.4	94
37	0.20	0.58	1.0	1.7	2.6	3.9	7.9	14.5	24.3	36.1	53.0	77
30	0.16	0.47	0.8	1.4	2.1	3.1	6.4	11.7	19.7	29.3	42.9	62.5
25	0.14	0.39	0.65	1.1	1.8	2.6	5.4	9.8	16.5	24.4	35.8	52.1
20	0.11	0.31	0.52	0.91	1.4	2.1	4.3	7.8	13.2	19.5	28.6	41.6
16.5	0.090	0.26	0.43	0.75	1.2	1.7	3.5	6.4	10.9	16.1	23.6	34.4
13.5	0.074	0.21	0.35	0.61	0.97	1.4	2.9	5.3	8.9	13.2	19.3	28.1
11	0.060	0.17	0.29	0.50	0.79	1.1	2.4	4.3	7.2	10.7	15.7	22.9
9	0.049	0.14	0.23	0.41	0.64	0.94	1.9	3.5	5.9	8.8	12.9	18.7
7.5	0.041	0.12	0.20	0.34	0.54	0.78	1.6	2.9	4.9	7.3	10.7	15.6
5	0.027	0.08	0.13	0.23	0.36	0.52	1.1	2.0	3.3	4.9	7.2	10.4

T20 Only.

- B. Check shaft diameters against coupling maximum bores shown in Tables 15 thru 18 for the type of coupling selected. If a larger bore is required, select a larger coupling.
- C. Check the required speed against the allowable speed shown in Table 1 for the type of coupling selected. For Type T50 Floating Shaft design, check the allowable speed from Table 12 on Page 29. If a higher speed is required, refer application details to the local Rexnord Representative.
- D. Check application dimension requirements against selected coupling type dimensions shown on Pages 14 thru 35.

Example:

Select a Steelflex coupling to connect the low speed shaft of a gear drive to a belt conveyor. The motor is 250 kW and the low speed shaft RPM is 68. The gear drive shaft is 160 mm and the conveyor shaft is 180 mm.

1. Select Coupling Type — To connect close coupled shafts, and to accommodate anticipated shaft misalignment, the double engagement Type T10 coupling shown on Page 14, is the selection.
2. Determine Service Factor — From Table 4, Page 12, the service factor is 1.0.
3. Determine Equivalent HP — From Table 2, Page 10, the equivalent power is 250 kW.
4. Select coupling Size — (A) From Table 3, Page 11, the coupling size is 1150T10 for 68RPM. (B) From Table 3, the maximum bore of 215 mm, and allowable speed of 1500 rpm are all satisfactory. Check other dimensional information on Page 14 against the available shaft lengths, shaft gaps, and diameter restrictions.

TABLE 3 — Coupling Selection . . . Based on Equivalent kW Ratings (Continued)

	1140T	1150T	1160T	1170T	1180T	1190T	1200T	1210T	1220T	1230T	1240T	1250T	1260
Max Bore (mm)	200	215	240	280	300	335	360	390	420	450	480	*	*
Max Speed T10	1650 rpm	1500 rpm	1350 rpm	1225 rpm	1100 rpm	1050 rpm	900 rpm	820 rpm	730 rpm	680 rpm	630 rpm	580 rpm	540 rpm
Max Speed T20	2200 rpm	2000 rpm	1800 rpm	1600 rpm
Torque (Nm)	28585	39770	55930	74570	103400	136710	186430	248570	335570	435000	559300	745700	932100
kW / rpm	2,99	4,16	5,86	7,81	10,8	14,3	19,5	26	35,1	45,6	58,6	78,1	97,6
RPM	kW Ratings												
4500													
3600													
3000													
2500													
2100	6300	8760											
1800	5400	7510	10500										
1750	5250	7300		13700									
1450	4350	6050	8490	11300									
1170	3510	4880	6850	9140									
1000	3000	4170	5860	7810	10800	14300							
870	2610	3630	5100	6790	9420	12500	17000						
720	2160	3000	4220	5620	7800	10300	14100	18800	25300				
650	1950	2710	3810	5080	7040	9310	12700	17000	22900	29600			
580	1740	2420	3400	4530	6280	8300	11300	15100	20400	26400	33900	45300	
520	1560	2170	3050	4060	5630	7440	10200	13600	18300	23700	30400	40600	50800
420	1260	1750	2460	3280	4550	6010	8200	11000	14800	19100	24600	32800	41000
350	1050	1460	2050	2730	3790	5010	6830	9140	12300	15900	20500	27300	34200
280	840	1170	1640	2190	3030	4010	5470	7310	9860	12800	16400	21900	27300
230	690	959	1350	1800	2490	3290	4490	6000	8100	10500	13500	18000	22500
190	570	792	1110	1480	2060	2720	3710	4960	6690	8660	11100	14800	18500
155	465	646	908	1210	1680	2220	3030	4050	5460	7060	9070	12100	15100
125	375	521	732	976	1350	1790	2440	3260	4400	5690	7310	9760	12200
100	300	417	586	781	1080	1430	1950	2610	3520	4560	5850	7810	9760
84	252	350	492	656	910	1200	1640	2190	2960	3830	4910	6560	8200
68	204	284	398	531	736	974	1330	1770	2390	3100	3980	5310	6640
56	168	234	328	437	606	802	1090	1460	1970	2550	3280	4370	5470
45	135	188	264	351	487	644	879	1170	1580	2050	2630	3510	4390
37	111	154	217	289	401	530	722	966	1300	1690	2160	2890	3610
30	90.0	125	176	234	325	429	586	783	1060	1370	1760	2340	2930
25	75.0	104	146	195	271	358	488	653	880	1140	1460	1950	2440
20	60.0	83	117	156	217	286	390	522	704	911	1170	1560	1950
16.5	49.5	68.8	97	129	179	236	322	431	581	752	965	1290	1610
13.5	40.5	56.3	79	105	146	193	264	352	475	615	790	1050	1320
11	33.0	45.9	64.4	85.9	119	157	215	287	387	501	644	859	1070
9	27.0	37.5	52.7	70.3	97	129	176	235	317	410	527	703	878
7.5	22.5	31.3			81	107	146	196	264	342	439	586	732
5	15.0	20.9	29.3	39.0	54	72	98	131	176	228	293	390	488

* Refer to Falk.
 ■ T20 Only.

Service Factors

TABLE 4 — Flexible Coupling Service Factors for Motor ♦ and Turbine Drives

Service factors listed are typical values based on normal operation of the drive systems.

Alphabetical listing of applications

AERATOR	2.0
AGITATORS	
Vertical and Horizontal	
Screw, Propeller, Paddle	1.0
BARGE HAUL PULLER	1.5
BLOWERS	
Centrifugal	1.0
Lobe or Vane	1.25
CAR DUMPERS	2.5
CAR PULLERS	1.5
CLARIFIER OR CLASSIFIER	1.0
COMPRESSORS	
Centrifugal	1.0
Rotary, Lobe or Vane	1.25
Rotary, Screw	1.0
Reciprocating	
Direct Connected	Refer to Factory
Without Flywheel	Refer to Factory
*With Flywheel and Gear	
between Compressor	
and Prime Mover	
1 cylinder, single acting	3.0
1 cylinder, double acting	3.0
2 cylinders, single acting	3.0
2 cylinders, double acting	3.0
3 cylinders, single acting	3.0
3 cylinders, double acting	2.0
4 or more cyl., single act.	1.75
4 or more cyl., double act.	1.75
▲ CONVEYORS	
Apron, Assembly, Belt, Chain,	
Flight, Screw	1.0
Bucket	1.25
Live Roll, Shaker and	
Reciprocating	3.0
♠ CRANES AND HOIST	
Main Hoist	1.75▲
Skip Hoist	1.75▲
Slope	1.5
Bridge, Travel or Trolley	1.75
DYNAMOMETER	1.0
ELEVATORS	
Bucket, Centrifugal Discharge	1.25
Freight or Passenger	Not Approved
Gravity Discharge	1.25
ESCALATORS	Not Approved
EXCITER, GENERATOR	1.0
EXTRUDER, PLASTIC	1.5
FANS	
Centrifugal	1.0
Cooling Tower	2.0
Forced Draft — Across the	
Line start	1.5
Forced Draft Motor	
Driven thru fluid or	
electric slip clutch	1.0
Gas Recirculating	1.5
Induced Draft with damper	
control or blade cleaner	1.25
Induced Draft without controls	2.0
FEEDERS	
Apron, Belt, Disc, Screw	1.0
Reciprocating	2.5
GENERATORS	
Even Load	1.0
Hoist or Railway Service	1.5

Welder Load	2.0
HAMMERMILL	1.75
LAUNDRY WASHER OR	
TUMBLER	2.0
LINE SHAFTS	
Any Processing Machinery	1.5
MACHINE TOOLS	
Auxiliary and Traverse Drive	1.0
Bending Roll, Notching Press,	
Punch Press, Planer, Plate	
Reversing	1.75
Main Drive	1.5
MAN LIFTS	Not Approved
METAL FORMING MACHINES	
Continuous Caster	1.75
Draw Bench Carriage and	
Main Drive	2.0
Extruder	2.0
Farming Machine and	
Forming Mills	2.0
Slitters	1.0
Wire Drawing or Flattening	1.75
Wire Winder	1.5
Coilers and Uncoilers	1.5
MIXERS (see Agitators)	
Concrete	1.75
Muller	1.5
PRESS, PRINTING	1.5
PUG MILL	1.75
PULVERIZERS	
Hammermill and Hog	1.75
Roller	1.5
PUMPS	
Boiler Feed	1.5
Centrifugal —	
Constant Speed	1.0
Frequent Speed Changes	
under Load	1.25
Descaling, with accumulators	1.25
Gear, Rotary, or Vane	1.25
Reciprocating, Plunger Piston	
1 cyl., single or double act.	3.0
2 cyl., single acting	2.0
2 cyl., double acting	1.75
3 or more cylinders	1.5
Screw Pump, Progressing Cavity	1.25
Vacuum Pump	1.25
SCREENS	
Air Washing	1.0
Grizzly	2.0
Rotary Coal or Sand	1.5
Vibrating	2.5
Water	1.0
SKI TOWS & LIFTS	Not Approved
STEERING GEAR	1.0
STOKER	1.0
TIRE SHREDDER	1.50
TUMBLING BARREL	1.75
WINCH, MANEUVERING	
Dredge, Marine	1.5
WINDLASS	1.5
WOODWORKING	
MACHINERY	1.0
WORK LIFT PLATFORMS	Not Approved

♦ For engine drives, refer to Table 5. Electric motors, generators, engines, compressors and other machines fitted with sleeves or straight roller bearings usually require limited end float couplings. If in doubt, provide axial clearances and centering forces to the Factory for a recommendation.

* For balanced opposed design, refer to the Factory.

▲ If people are occasionally transported, refer to the Factory for the selection of the proper size coupling.

♠ For high peak load applications (such as Metal Rolling Mills) refer to the Factory.

TABLE 5 — Engine Drive Service Factors ♥

Service Factors for engine drives are those required for applications where good flywheel regulation prevents torque fluctuations greater than ±20%. For drives where torque fluctuations are greater or where the operation is near a serious critical or torsional vibration, a mass elastic stud is necessary.

No. of Cylinders	4 or 5 ♥					6 or more ♥				
	1.0	1.25	1.5	1.75	2.0	1.0	1.25	1.5	1.75	2.0
Table 2 S.F.	1.0	1.25	1.5	1.75	2.0	1.0	1.25	1.5	1.75	2.0
Engine S.F.	2.0	2.25	2.5	2.75	3.0	1.5	1.75	2.0	2.25	2.5







♥ To use Table 5, first determine application service factor from Table 4. Use that factor to determine ENGINE Service Factor from Table 5. When service factor from Table 4 is greater than 2.0, or where 1, 2, or 3 cylinder engines are involved, refer complete application details to Rexnord Engineering.

Alphabetical listing of industries

AGGREGATE PROCESSING, CEMENT, MINING KILNS; TUBE, ROD AND BALL MILLS	
Direct or on L.S. shaft of	
Reducer, with final drive	
Machined Spur Gears	2.0
Single Helical or	
Herringbone Gears	1.75
Conveyors, Feeders, Screens,	
Elevators	See General Listing
Crushers, Ore or Stone	2.5
Dryer, Rotary	1.75
Grizzly	2.0
Hammermill or Hog	1.75
Tumbling Mill or Barrel	1.75
BREWING AND DISTILLING	
Bottle and Can	
Filling Machines	1.0
Brew Kettle	1.0
Cookers, Continuous Duty	1.25
Lauter Tub	1.5
Mash Tub	1.25
Scale Hopper, Frequent Peaks	1.75
CLAY WORKING INDUSTRY	
Brick Press, Briquette Machine,	
Clay Working Machine,	
Pug Mill	1.75
DREDGES	
Cable Reel	1.75
Conveyors	1.25
Cutter head, Jig Drive	2.0
Maneuvering Winch	1.5
Pumps (uniform load)	1.5
Screen Drive, Stacker	1.75
Utility Winch	1.5
FOOD INDUSTRY	
Beet Slicer	1.75
Bottling, Can Filling Machine	1.0
Cereal Cooker	1.25
Dough Mixer, Meat Grinder	1.75
LUMBER	
Band Resaw	1.5
Circular Resaw, Cut-off	1.75
Edger, Head Rig, Hog	2.0
Gang Saw	
(Reciprocating)	Refer to Factory
Log Haul	2.0
Planer	1.75
Rolls, Non-Reversing	1.25
Rolls, Reversing	2.0
Sawdust Conveyor	1.25
Slab Conveyor	1.75
Sorting Table	1.5
Trimmer	1.75
♠ METAL ROLLING MILLS	
Coilers (Up or Down) Cold	
Mills only	1.5
Coilers (Up or Down) Hot	
Mills only	2.0
Coke Plants	
Pusher Ram Drive	2.5
Door Opener	2.0
Pusher or Larry Car	
Traction Drive	3.0
Continuous Caster	1.75
Cold Mills —	
Strip Mills	Refer to Factory
Temper Mills	Refer to Factory
Cooling Beds	1.5
Drawbench	2.0
Feed Rolls - Blooming Mills	3.0
Furnace Pushers	2.0
Hot and Cold Saws	2.0
Hot Mills —	
Strip or Sheet Mills	Refer to Factory
Reversing Blooming	Refer to Factory
or Slabbing Mills	Refer to Factory
Edger Drives	Refer to Factory
Ingot Cars	2.0
Manipulators	3.0
Merchant Mills	Refer to Factory
Mill Tables	
Roughing Breakdown	
Mills	3.0
Hot Bed or Transfer,	
non-reversing	1.5
Runout, reversing	3.0
Runout, non-reversing,	
non-plugging	2.0
Reel Drives	1.75
Rod Mills	Refer to Factory
Screwdown	2.0
Seamless Tube Mills	
Piercer	3.0
Thrust Block	2.0
Tube Conveyor Rolls	2.0
Reeler	2.0
Kick Out	2.0
Shear, Croppers	Refer to Factory
Sidguards	3.0
Skelp Mills	Refer to Factory

Slitters, Steel Mill only	1.75
Soaking Pit Cover Drives —	
Lift	1.0
Travel	2.0
Straighteners	2.0
Unscramblers (Billet Bundle	
Busters)	2.0
Wire Drawing Machinery	1.75
OIL INDUSTRY	
Chiller	1.25
Oil well Pumping (not over	
150% peak torque)	2.0
Paraffin Filter Press	1.5
Rotary Kiln	2.0
PAPER MILLS	
Barker Auxiliary, Hydraulic	2.0
Barker, Mechanical	2.0
Barking Drum	
L.S. shaft of reducer with	
final drive - Helical	
or Herringbone Gear	2.0
Machined Spur Gear	2.5
Cast Tooth Spur Gear	3.0
Beater & Pulper	1.75
Bleachers, Coaters	1.0
Calender & Super Calender	1.75
Chipper	2.5
Converting Machine	1.25
Couch	1.75
Cutter, Felt Whipper	2.0
Cylinder	1.75
Dryer	1.75
Felt Stretcher	1.25
Fourdrinier	1.75
Jordan	2.0
Log Haul	2.0
Line Shaft	1.5
Press	1.75
Pulp Grinder	1.75
Reel, Rewinder, Winder	1.5
Stock Chest, Washer,	
Thickener	1.5
Stock Pumps, Centrifugal	
Constant Speed	1.0
Frequent Speed Changes	
Under Load	1.25
Suction Roll	2.0
Vacuum Pumps	1.75
RUBBER INDUSTRY	
Calender	2.0
Cracker, Plasticator	2.5
Extruder	1.75
Intensive or Banbury Mixer	2.5
Mixing Mill, Refiner or Sheeter	
One or two in line	2.5
Three or four in line	2.0
Five or more in line	1.75
Tire Building Machine	2.5
Tire & Tube Press Opener	
(Peak Torque)	1.0
Tuber, Strainer, Pelletizer	1.75
Warming Mill	
One or two Mills in line	2.0
Three or more Mills in line	1.75
Washer	2.5
SEWAGE DISPOSAL EQUIPMENT	
Bar Screen, Chemical Feeders,	
Collectors, Dewatering	
Screen, Grit Collector	1.0
SUGAR INDUSTRY	
Cane Carrier & Leveler	1.75
Cane Knife & Crusher	2.0
Mill Stands, Turbine Driver	
With all helical or	
Herringbone gears	1.5
Electric Drive or Steam Engine	
Drive with Helical,	
Herringbone, or Spur Gears	
with any Prime Mover	1.75
TEXTILE INDUSTRY	
Batcher	1.25
Calender, Card Machine	1.5
Cloth Finishing Machine	1.5
Dry Can, Loom	1.5
Dyeing Machinery	1.25
Knitting Machine	Refer to Factory
Mangle, Napper, Soaper	1.25
Spinner, Tenter Frame, Winder	1.5

SERVICE FACTORS are a guide, based on experience, of the ratio between coupling catalog rating and system characteristics. The system characteristics are best measured with a torque meter.

Torque Demands Driven Machine	Typical applications for electric motor or turbine driven equipment	Typical Service Factor
	Constant Torque such as Centrifugal Pumps, Blowers, and Compressors.	1.0
	Continuous duty with some torque variations including Plastic Extruders, Forced Draft Fans.	1.5
	Light shock loads from Metal Extruders, Cooling Towers, Cane Knife, Log Haul.	2.0
	Moderate shock loading as expected from a Car Dumper, Stone Crusher, Vibrating Screen.	2.5
	Heavy shock load with some negative torques from Roughing Mills, Reciprocating Pumps, Compressors, Reversing Runout Tables,	3.0
	Applications like Reciprocating Compressors with frequent torque reversals, which do not necessarily cause reverse rotations.	Consult Rexnord Engineering

How to Order

The following information is necessary to quote or ship to your exact requirements. Prompt service is assured if this information is given on your inquiry or order.

- Application: Driver & Driven
- Power: Normal kW, Maximum kW or Torque (Nm)
- Speed (RPM)
- For Type T63 Disc Brake Couplings, furnish brake requirements.
 - Holding torque requirement.
 - WR^2 of rotating parts (at brake location.)
 - Frequency of stops.
 - Rate of deceleration required — desired stop time and stopping rpm.
- Quantity
- Coupling Size and Type e.g., 110T41 or 1070T10
- Shaft Gap or distance between shaft ends (BE Dimension)
- Bore Sizes: Must Specify clearance or interference fit, or fit will be furnished per Table 27, Page 43. Bore sizes will be furnished as per Tables 29 or 30 on Pages 43-45 unless specified differently.
- Shaft Dimensions as follows:

For Straight Shafts:

Driving Shaft	Driven Shaft
Diameter U _____	Diameter U _____
Tolerance _____	Tolerance _____
Length V _____	Length V _____
Keyway _____	Keyway _____

NOTE: Provide shaft tolerances if different than those shown in Tables 28 thru 30, Pages 43-45. Unless otherwise specified, metric keyways will be furnished per ISO/R773-1969 and J_S9 width tolerances. Keyway sizes in inch shafts will be furnished based on key sizes listed in Table 13, Page 36, to Rexnord tolerances. For other shaft/bore requirements, consult Factory.

For Taper Shafts: keyway is assumed to be parallel to the bore.

Diameter U _____	Across Flats _____
Length V _____	Corners ZW _____
Length W _____	Taper _____
Length X _____	Keyway _____
Length Y _____	

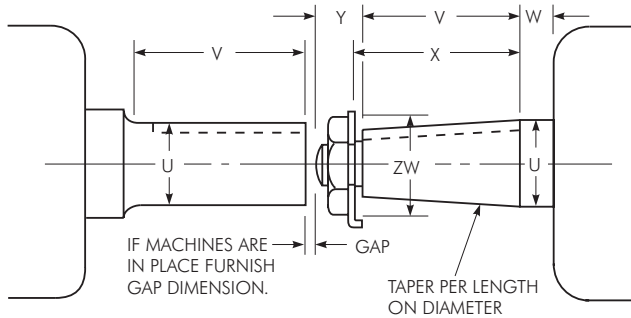

Type T10

Close Coupled/Dimensions — Millimeters

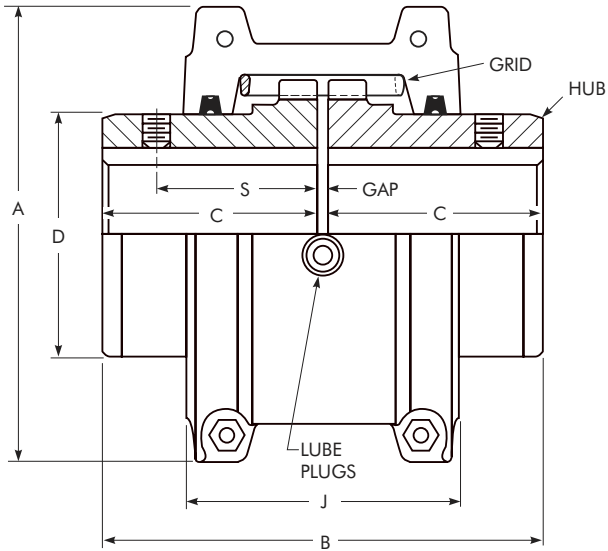

COVER PROFILES – HORIZONTAL SPLIT

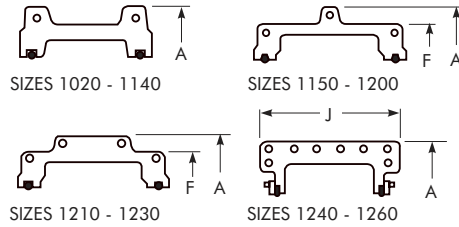

Sizes 1020 thru 1230T10 covers are cast aluminum alloy;
 Sizes 1240 thru 1260T10 are fabricated steel.

Type HD size range is from 1070-1140 as shown in screens below. Covers are powder-coated and seals are Nitrile.

SIZE ★	Torque Rating Nm †	Allow Speed rpm ‡	Max Bore mm ●	Min Bore mm ■	Cplg Wt With No Bore-kg	Lube Wt kg	DIMENSIONS — MILLIMETERS							
							A	B	C	D	F	J	S	Gap
1020T	52	4500	28	13	1,92	0,0272	97,0	98,2	47,6	39,7	66,7	39,1	3
1030T	149	4500	35	13	2,58	0,0408	105,7	98,2	47,6	49,2	68,3	39,1	3
1040T	249	4500	43	13	3,34	0,0544	114,3	104,6	50,8	57,2	69,9	40,1	3
1050T	435	4500	50	13	5,44	0,0680	135,1	123,6	60,3	66,7	80,9	44,7	3
1060T	684	4350	56	20	7,44	0,0862	147,8	130,0	63,5	76,2	93,5	52,3	3
1070T	994	4125	67	20	10,4	0,113	158,8	155,4	76,2	87,3	96,8	53,8	3
1080T	2 050	3600	80	27	17,9	0,172	190,5	180,8	88,9	104,8	115,6	64,5	3
1090T	3 730	3600	95	27	25,6	0,254	211,1	199,8	98,4	123,8	122,2	71,6	3
1100T	6 280	2440	110	42	42,0	0,426	251,0	246,2	120,6	142,1	155,4	5
1110T	9 320	2250	120	42	54,3	0,508	269,7	259,0	127,0	160,3	161,5	5
1120T	13 700	2025	140	61	81,2	0,735	307,8	304,4	149,2	179,4	191,5	6
1130T	19 900	1800	170	67	121	0,907	345,9	329,8	161,9	217,5	195,1	6
1140T	28 600	1650	200	67	178	1,13	384,0	374,4	184,2	254,0	201,2	6
1150T	39 800	1500	215	108	234	1,95	453,1	371,8	182,9	269,2	391,2	271,5	6
1160T	55 900	1350	240	121	317	2,81	501,9	402,2	198,1	304,8	436,9	278,4	6
1170T	74 600	1225	280	134	448	3,49	566,9	437,8	215,9	355,6	487,2	307,3	6
1180T	103 000	1100	300	153	619	3,76	629,9	483,6	238,8	393,7	554,7	321,1	6
1190T	137 000	1050	335	153	776	4,40	675,6	524,2	259,1	436,9	607,8	325,1	6
1200T	186 000	900	360	178	1 058	5,62	756,9	564,8	279,4	497,8	660,4	355,6	6
1210T	249 000	820	390	178	1 424	10,5	844,6	622,6	304,8	533,4	750,8	431,8	13
1220T	336 000	730	420	203	1 785	16,1	920,8	663,2	325,1	571,5	822,2	490,2	13
1230T	435 000	680	450	203	2 267	24,0	1 003,3	703,8	345,4	609,6	904,7	546,1	13
1240T	559 000	630	480	254	2 950	33,8	1 087,1	749,6	368,3	647,7	647,7	13
1250T	746 000	580	◆	254	3 833	50,1	1 181,1	815,6	401,3	711,2	698,5	13
1260T	932 000	540	◆	254	4 682	67,2	1 260,9	876,6	431,8	762,0	762,0	13

★ Refer to Page 5 for General Information and Reference Notes.
 ◆ Refer to the Factory.

Type T20

Close Coupled/Dimensions — Millimeters

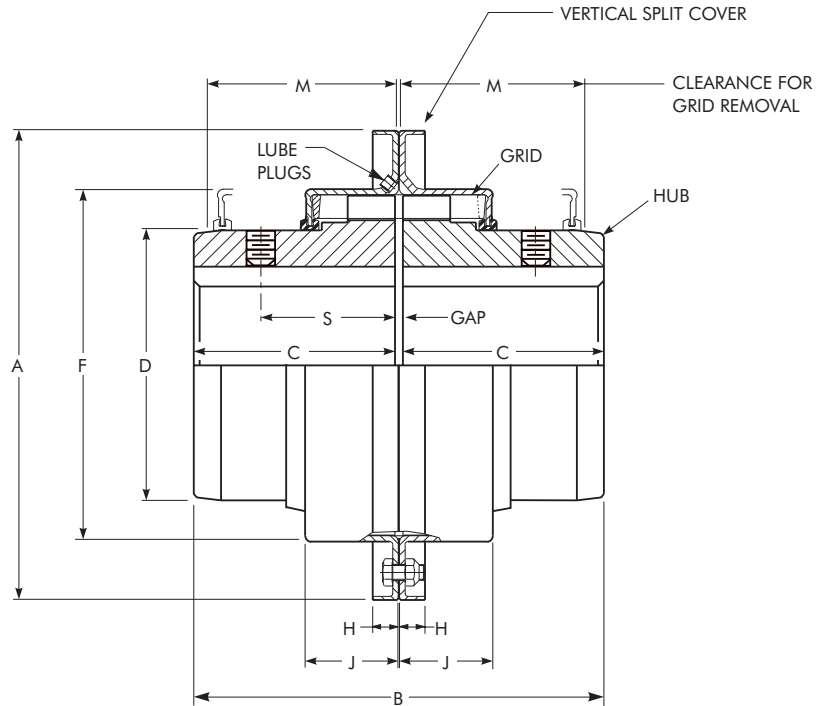

SIZE ★	Torque Rating Nm †	Allow Speed rpm ‡	Max Bore mm ●	Min Bore mm ■	Cplg Wt Without Bore-kg	Lube Wt kg	DIMENSIONS — MILLIMETERS									
							A	B	C	D	F	H	J	M	S	Gap
1020T	52	6000	28	13	1,94	0,0272	112,3	98,2	46,7	39,7	64,3	9,7	23,9	47,8	39,1	3
1030T	149	6000	35	13	2,58	0,0408	121,8	98,2	46,7	49,2	73,8	9,7	24,9	47,8	39,1	3
1040T	249	6000	43	13	3,35	0,0544	129,8	104,6	50,8	57,2	81,8	9,7	25,9	50,8	40,1	3
1050T	435	6000	50	13	5,32	0,0680	148,8	123,6	60,3	66,7	97,6	11,9	30,5	60,5	44,7	3
1060T	684	6000	56	20	7,01	0,0862	163,1	130,0	63,5	76,2	111,1	12,7	31,8	63,5	52,3	3
1070T	994	5500	67	20	10,2	0,113	174,2	155,4	76,2	87,3	122,3	12,7	33,5	66,5	53,8	3
1080T	2 050	4750	80	27	17,6	0,172	201,2	180,8	88,9	104,8	149,2	12,7	43,7	88,9	64,5	3
1090T	3 730	4000	95	27	25,4	0,254	232,9	199,8	98,4	123,8	168,3	12,7	47,0	95,2	71,6	3
1100T	6 280	3250	110	42	42,0	0,426	267,9	246,2	120,6	142,1	198,0	15,7	59,7	120,7	5
1110T	9 320	3000	120	42	54,4	0,508	286,9	259,0	127,0	160,3	216,3	16,0	62,7	124,0	5
1120T	13 700	2700	140	61	81,8	0,735	320,2	304,4	149,2	179,4	245,5	17,5	73,7	142,7	6
1130T	19 900	2400	170	67	122	0,907	379,0	329,8	161,9	217,5	283,8	20,6	74,9	146,0	6
1140T	28 600	2200	200	67	180	1,13	417,1	374,4	184,2	254,0	321,9	20,6	78,2	155,4	6
1150T	39 800	2000	215	108	230	1,95	476,2	371,8	182,9	269,2	374,4	19,3 ♦	107,3	203,2	6
1160T	55 900	1750	240	121	321	2,81	533,4	402,2	198,1	304,8	423,9	30,0 ♦	115,3	215,9	6
1170T	74 600	1600	280	134	448	3,49	584,2	437,8	215,9	355,6	474,7	30,0 ♦	120,1	226,1	6

★ Refer to Page 5 for General Information and Reference Notes.

♦ Dimension "H" is to the end of the bolt on Sizes 1150 thru 1170. Bolts are not shrouded.

Type T31

Full Spacer/Dimensions — Millimeters

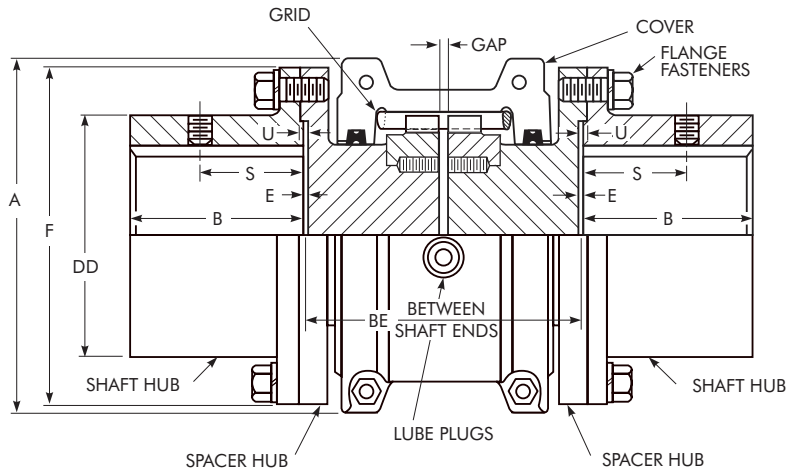

SIZE ★	Torque Rating Nm †	Allow Speed rpm ‡	Max Bore mm •	Min Bore mm ■	Cplg Wt With No Bore & Min BE kg	Wt Added Per mm of BE Over Minimum	Lube Wt kg	DIMENSIONS — MILLIMETERS											Flange Fasteners	
								A	B	BE		DD	E	F	S	U	Gap	No. per Flange & SAE Grade	Dia Inches	
										Min	Max									
1020T	52	3600	35	13	3,85	0,010	0,0272	97,0	34,9	88,9	203	52,4	0,8	85,7	27,4	1,8	5	4 — Gr 8	.250	
1030T	149	3600	43	13	5,21	0,016	0,0408	105,7	41,3	88,9	216	59,5	0,8	93,7	31,5	1,8	5	8 — Gr 8	.250	
1040T	249	3600	56	13	8,43	0,021	0,0544	114,3	54,0	88,9	216	78,6	0,8	112,7	27,4	1,8	5	8 — Gr 8	.250	
1050T	435	3600	67	13	12,8	0,028	0,0680	135,1	60,3	111,1	216	87,3	0,8	125,4	40,6	1,8	5	8 — Gr 8	.312	
1060T	684	3600	80	20	20,5	0,037	0,0862	147,8	73,0	122,2	330	103,2	1,8	144,5	43,2	2,8	5	8 — Gr 8	.375	
1070T	994	3600	85	20	24,8	0,048	0,113	158,8	79,4	127,0	330	109,5	1,8	152,4	46,7	2,8	5	12 — Gr 8	.375	
1080T	2 050	3600	95	27	40,0	0,069	0,172	190,5	88,9	155,5	406	122,2	1,8	177,8	49,8	2,8	5	12 — Gr 5	.500	
1090T	3 730	3600	110	27	60,1	0,10	0,254	211,1	101,6	163,5	406	142,9	1,8	209,6	56,9	2,8	5	12 — Gr 5	.625	
1100T	6 280	2440	130	39	90,2	0,12	0,426	251,0	90,4	203,2	406	171,4	1,6	250,8	...	3,2	6	12 — Gr 5	.750	
1110T	9 320	2250	150	51	119	0,16	0,508	269,7	104,1	209,6	406	196,8	1,6	276,2	...	3,2	6	12 — Gr 5	.750	
1120T	13 700	2025	170	64	178	0,20	0,735	307,8	119,4	246,1	406	225,4	1,6	319,1	...	4,0	10	12 — Gr 5	.875	
1130T	19 900	1800	190	77	237	0,29	0,907	345,9	134,6	257,1	406	238,1	1,6	346,1	...	4,0	10	12 — Gr 5	1.000	
1140T	28 600	1650	210	89	327	0,40	1,13	384,0	152,4	266,7	406	266,7	1,6	385,8	...	4,0	10	12 — Gr 5	1.125	

★ Refer to Page 5 for General Information and Reference Notes.

**TABLE 6 — Type T31 Standard Stock Spacer Lengths
(BE = Distance Between Shaft Ends)**

Between Shaft Ends		Pump Std	COUPLING SIZE										
Millimeters	Inch		1020T	1030T	1040T	1050T	1060T	1070T	1080T	1090T	1100T	1110T	
89	3.5	ANSI	X	X	X								
100	3.94	ISO	X	X	X								
108	4.25	MISC	X	X	X								
111	4.38	ANSI	X	X	X	X							
119	4.69	MISC	X	X	X	X							
127	5.00	ANSI	X	X	X	X	X		X				
133	5.22	MISC	X								
137	5.38	MISC	...	X	X								
140	5.51	ISO	X	X	X	X	X		X				
144	5.66	MISC	...	X	X								
148	5.81	MISC	...	X	X	X							
152	5.97	MISC	X	X							
155	6.12	MISC	...	X	X	X	X		X				
176	6.94	MISC	X	X	X	X	X						
178	7.00	ANSI	X	X				
180	7.09	ISO	X	X	...	X	X	X			
184	7.25	ANSI	...	X	X	X	X	X	X				
203	8.00	MISC	X			
218	8.59	MISC	X				
219	8.62	MISC	X	X				
226	8.88	MISC	X		
248	9.75	ANSI	X	X	X	X	X	
250	9.84	ISO	X	X	
252	9.94	MISC	X			
282	11.09	MISC	X				
311	12.25	ANSI	X	X	X			
357	14.05	MISC	X	

Type T31

Full Spacer/Dimensions — Millimeters

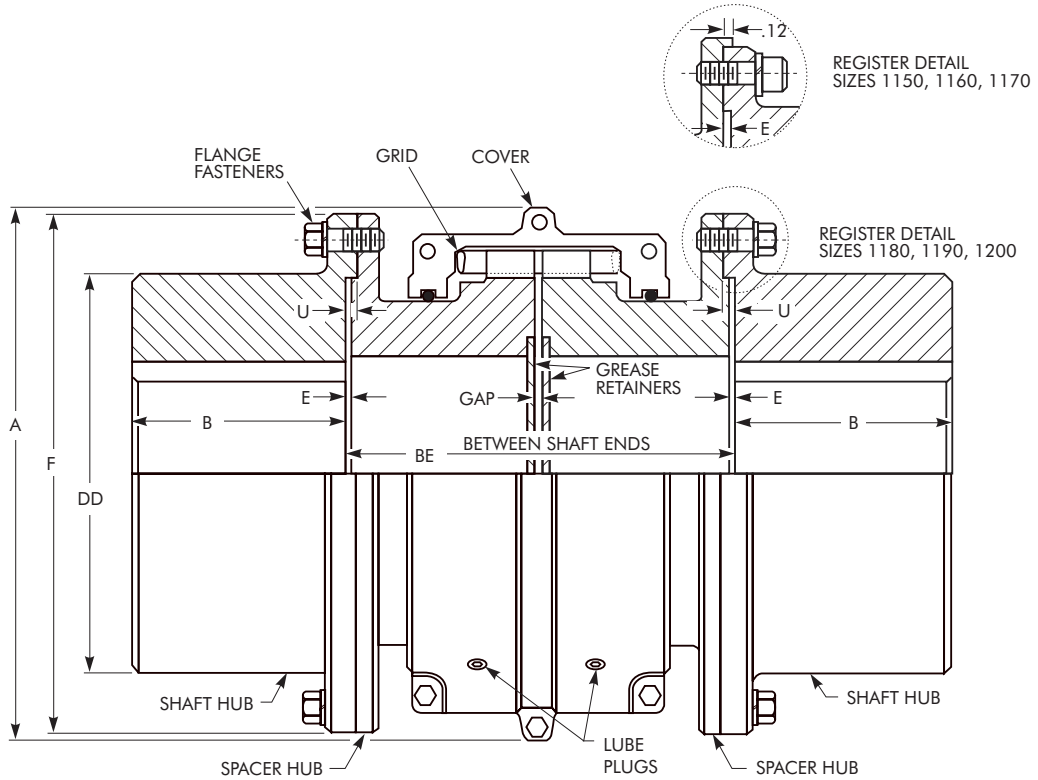

SIZE ★	G52 Rigid Hub Size *	Torque Rating Nm †	Allow Speed rpm ‡	Max Bore mm ●	Min Bore mm ■	Cplg Wt With No Bore & Min BE kg	Wt Added Per mm of BE Over Minimum	Lube Wt kg	DIMENSIONS — MILLIMETERS										Flange Fasteners	
									A	B	BE		DD ◆	E	F	U	Gap	No. per Flange & SAE Grade	Dia Inches	
											Min	Max								
1150T	1055G	39 800	1500	270	102	462	0,19	1,95	453,1	172,7	344,5	371,3	334,3	5,1	425,4	...	10	14 — Gr 8	.875	
1160T	1060G	55 900	1350	290	115	566	0,25	2,81	501,4	186,4	355,6	406,4	366,0	6,6	457,2	...	10	14 — Gr 8	.875	
1170T	1070G	74 600	1225	340	127	856	0,38	3,49	566,4	220,2	384,2	444,5	424,9	8,4	527,0	...	10	16 — Gr 8	1.000	
1180T	1080G	103 000	1100	340	102	1 135	0,47	3,76	629,9	248,9	400,1	490,5	450,8	5,1	590,6	8,1	10	16 — Gr 5	1.125	
1190T	1090G	137 000	1050	380	115	1 525	0,60	4,40	675,6	275,8	411,2	530,4	508,0	5,1	660,4	8,1	10	18 — Gr 5	1.250	
1200T	1100G	186 000	900	400	127	1 910	0,85	5,62	756,9	305,3	444,5	574,5	530,4	6,1	711,2	9,1	10	18 — Gr 5	1.250	

★ Refer to Page 5 for General Information and Reference Notes.

◆ Dimension DD is for an as-cast, unmachined surface for Sizes 1180, 1190, and 1200.

* Type T31 couplings shown use Type G52 gear coupling rigid hubs as the shaft hubs.

Type T35

Half Spacer/Dimensions — Millimeters

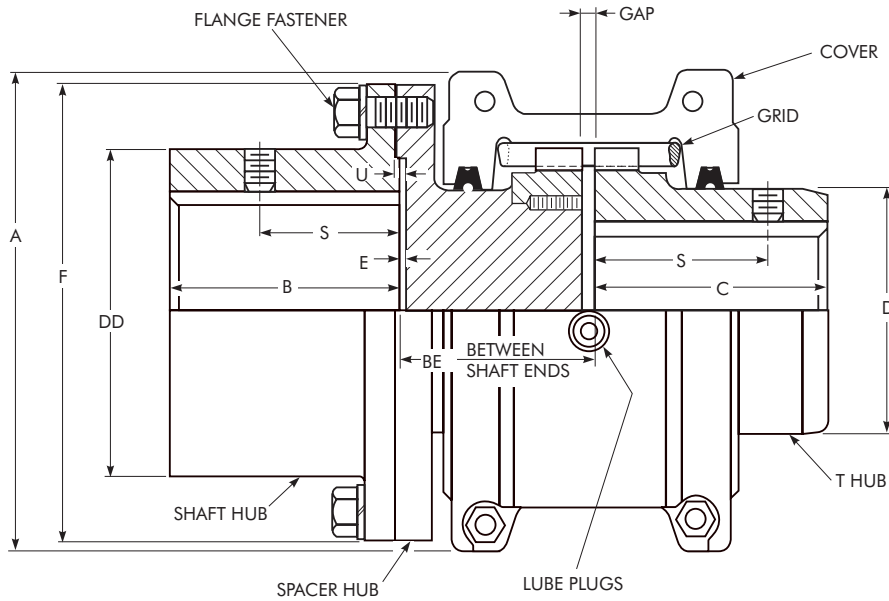

SIZE ★	Torque Rating Nm †	Allow Speed rpm ‡	Max Bore mm •		Min Bore mm ■	Cplg Wt With No Bore & Min BE kg	Wt Added Per mm of BE Over Minimum	Lube Wt kg	DIMENSIONS — MILLIMETERS													Flange Fasteners	
			Shaft Hub	T Hub					A	B	BE		C	D	DD	E	F	S		U	Gap	No. Per Flange & Grade	Dia Inches
											Min	Max						Shaft Hub	T Hub				
1020T	52	3600	35	28	13	2,89	0,010	0,0272	97,0	34,9	45,2	102	47,6	39,7	52,4	0,8	85,7	27,4	39,1	1,8	3	4—Gr 8	.250
1030T	149	3600	43	35	13	3,89	0,016	0,0408	105,7	41,3	45,2	109	47,6	49,2	59,5	0,8	93,7	31,5	39,1	1,8	3	8—Gr 8	.250
1040T	249	3600	56	43	13	5,88	0,021	0,0544	114,3	54,0	45,2	109	50,8	57,2	78,6	0,8	112,7	27,4	40,1	1,8	3	8—Gr 8	.250
1050T	435	3600	67	50	13	9,12	0,028	0,0680	135,1	60,3	56,3	109	60,3	66,7	87,3	0,8	125,4	40,6	44,7	1,8	3	8—Gr 8	.312
1060T	684	3600	80	56	20	13,9	0,037	0,0862	147,8	73,0	61,9	166	63,5	76,2	103,2	1,8	144,5	43,2	52,3	2,8	3	8—Gr 8	.375
1070T	994	3600	85	67	20	17,6	0,048	0,113	158,8	79,4	64,3	166	76,2	87,3	109,5	1,8	152,4	46,7	53,8	2,8	3	12—Gr 8	.375
1080T	2 050	3600	95	80	27	28,9	0,069	0,172	190,5	88,9	78,6	204	88,9	104,8	122,2	1,8	177,8	49,8	64,5	2,8	3	12—Gr 5	.500
1090T	3 730	3600	110	95	27	42,8	0,10	0,254	211,1	101,6	82,6	204	98,4	123,8	142,9	1,8	209,6	56,9	71,6	2,8	3	12—Gr 5	.625
1100T	6 280	2440	130	110	42 ♦	66,1	0,12	0,426	251,0	90,4	103,2	205	120,6	142,1	171,4	1,6	250,8	3,0	5	12—Gr 5	.750
1110T	9 320	2250	150	120	42 ♦	84,6	0,16	0,508	269,7	104,1	106,4	205	127,0	160,3	196,8	1,6	276,2	3,0	5	12—Gr 5	.750
1120T	13 700	2025	170	140	61 ♦	129	0,20	0,735	307,8	119,4	124,6	205	149,2	179,4	225,4	1,6	319,1	4,0	6	12—Gr 5	.875
1130T	19 900	1800	190	170	67 ♦	179	0,29	0,907	345,9	134,6	130,1	205	161,9	217,5	238,1	1,6	346,1	4,0	6	12—Gr 5	1.000
1140T	28 600	1650	210	200	67 ♦	252	0,40	1,130	384,0	152,4	134,9	205	184,2	254,0	266,7	1,6	358,8	4,0	6	12—Gr 5	1.125

★ Refer to Page 5 for General Information and Reference Notes.

♦ Minimum bores are for the T Hub. Shaft hub bores are 39, 51, 64, 77, and 89 respectively.

TABLE 7 — Type T35 Half Spacer Coupling Standard Stock Spacer Lengths

Between Shaft Ends		Pump Std	COUPLING SIZE *									
Millimeter	Inch		1020T	1030T	1040T	1050T	1060T	1070T	1080T	1090T	1100T	1110T
45	1.78	MISC	X	X	X							
56	2.22	MISC	X	X	X	X						
64	2.53	MISC	X	X	X	X	X	X				
71	2.79	MISC	X	X	X	X	X	X				
89	3.50	ANSI	X	X	X	X	X					
90	3.53	MISC	X	X	X			
93	3.66	MISC	...	X	X	X	X	X	X			
91	3.58	MISC	X	X	X			
103	4.06	MISC	X		
125	4.94	MISC	X	X	
127	5.00	ANSI	X	...	X	X	
140	5.51	ISO	X	X	X		
156	6.16	MISC	X	X	X	X		
157	6.19	MISC	X	X	
180	7.09	ISO	X	...	X	

* CAUTION: To permit removal of T35 shaft hub without moving connected equipment, select a half spacer with dimension BE (in Table 5) greater than dimension B (in uppermost table) or overhanging the shaft hub. Refer to the Factory for maximum overhang allowed.

Type T35

Half Spacer/Dimensions — Millimeters

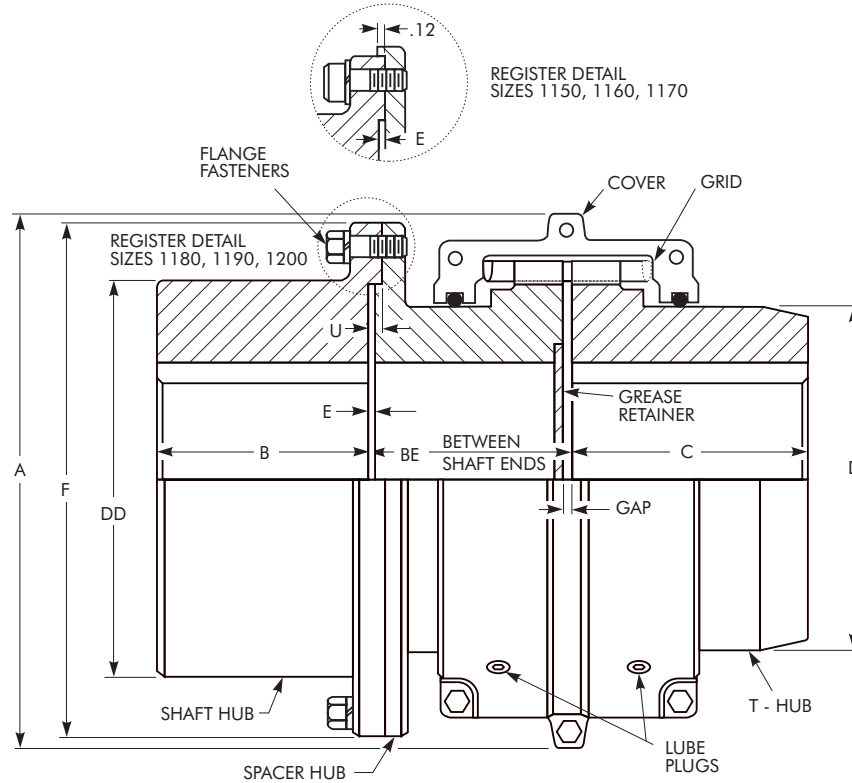

SIZE ★	G52 Rigid Hub Size *	Torque Rating Nm †	Allow Speed rpm ‡	Hub Bores				Cplg Wt With No Bore & Min BE kg	Wt Added Per mm of BE Over Minimum	Lube Wt kg	DIMENSIONS — MILLIMETERS											Flange Fasteners	
				Shaft Hub		T Hub					A	B	BE		C	D	DD ♦	E	F	U	Gap	No. Per Flange & Grade	Dia Inches
				Max mm ●	Min Bore mm ■	Max mm ●	Min Bore mm ■						Min	Max									
1150T	1055G	39 800	1500	270	102	215	108	348	0,19	1,95	453,1	172,7	174,5	187,5	182,9	269,2	334,3	5,1	425,4	...	6	14-Gr 8	.875
1160T	1060G	55 900	1350	290	115	240	121	441	0,25	2,81	501,4	186,4	179,6	204,7	198,1	304,8	366,0	6,6	457,2	...	6	14-Gr 8	.875
1170T	1070G	74 600	1225	340	127	280	134	652	0,38	3,49	566,4	220,2	194,1	223,8	215,9	355,6	424,9	8,4	527,0	...	6	16-Gr 8	1.000
1180T	1080G	103 000	1100	340	102	300	153	877	0,47	3,76	629,9	248,9	201,7	246,9	238,8	393,7	450,8	5,1	590,6	8,1	6	16-Gr 5	1.125
1190T	1090G	137 000	1050	380	115	335	153	1 150	0,60	4,40	675,6	275,8	207,3	266,7	259,1	436,9	508,0	5,1	660,4	8,1	6	18-Gr 5	1.250
1200T	1100G	186 000	900	400	127	360	178	1 484	0,85	5,62	756,9	305,3	223,8	289,1	279,4	497,8	530,4	6,1	711,2	9,1	6	18-Gr 5	1.250

★ Refer to Page 5 for General Information and Reference Notes.

♦ Dimension DD is for an as-cast, unmachined surface for Sizes 1180, 1190, and 1200T

* Type T35 couplings shown use Type G52 gear coupling rigid hubs as the shaft hubs.

Types T41, T41-2

Controlled Torque/Dimensions — Millimeters

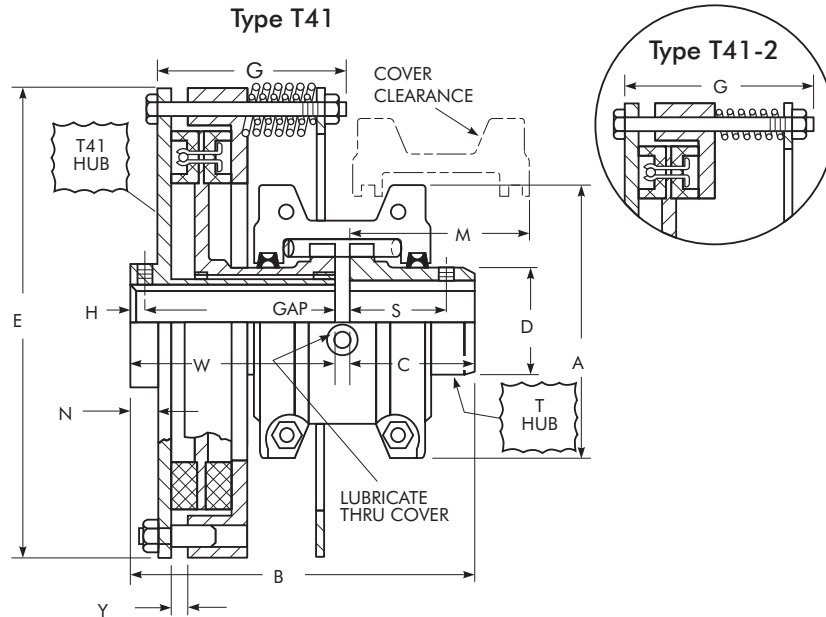

TABLE 8 — T41 Slip Torques, Bores & Speeds

SIZE ★	Cplg Wt ♦ w/o Bore-kg		Lube Wt kg	DIMENSIONS—MILLIMETERS												
	T41	T41-2		A	B	C	D	E	G	H	M ▲	N	S	W	Y ♣	Gap
20T	6,17	...	0,027	101,6	130,0	47,8	39,6	177,8	63,5	5,6	47,8	10,7	39,1	79,2	5,1	3
30T	8,16	8,16	0,041	111,3	130,0	47,8	49,3	201,7	69,6	5,6	50,8	10,7	39,1	79,2	5,1	3
40T	11,5	11,3	0,054	117,3	133,1	50,8	56,9	231,6	82,3	5,6	63,5	12,2	40,1	79,2	5,1	3
50T	16,4	16,0	0,068	138,2	150,9	60,5	66,5	270,3	82,3*	5,6	63,5	10,7	44,7	87,4	5,1	3
60T	22,0	21,3	0,086	150,9	163,1	63,5	76,2	301,2	88,9	8,1	76,2	15,2	52,3	96,5	5,1	3
70T	28,2	27,3	0,113	162,1	182,9	76,2	87,4	323,6	101,6	8,1	82,8	14,7	53,8	103,6	5,1	3
80T	41,0	40,3	0,172	193,5	206,2	88,9	104,6	361,7	101,6	8,1	91,9	14,7	64,5	114,3	5,1	3
90T	62,6	60,3	0,254	212,9	230,1	98,6	124,0	413,5	127,0	8,1	109,2	16,3	71,1	128,5	5,1	3
100T	101	91,6	0,426	251,0	269,2	120,7	142,2	491,2	139,7	...	147,3	20,8	...	143,8	5,3	5
110T	128	121	0,499	269,7	288,3	127,0	160,5	543,1	152,4	...	152,4	21,8	...	156,5	9,1	5
120T	183	174	0,726	307,8	341,1	149,4	179,3	590,3	177,8	...	177,8	26,9	...	185,4	9,1	6
130T	260	249	0,907	345,9	360,9	162,1	217,4	683,8	190,5	...	185,4	26,9	...	192,5	9,1	6
140T	376	360	1,13	384,0	389,1	184,2	254,0	766,6	203,2	...	213,4	27,2	...	198,6	8,9	6
150T	502	...	1,91	453,1	434,6	182,9	269,2	863,6	215,9	...	254,0	31,8	...	245,4	9,1	6
160T	652	...	2,81	501,4	454,9	198,1	304,8	988,6	215,9	...	254,0	32,3	...	250,4	9,1	6
170T	869	...	3,49	566,4	490,0	215,9	355,6	1 065,8	241,3	...	266,7	32,3	...	267,7	9,1	6
180T	1 161	...	3,76	629,9	536,7	238,8	393,7	1 160,8	241,3	...	266,7	42,7	...	291,6	9,1	6
190T	1 426	...	4,40	673,1	562,6	259,1	436,9	1 263,9	254,0	...	279,4	42,7	...	297,2	9,1	6
200T	1 805	...	5,62	756,9	601,2	279,4	497,8	1 377,2	254,0	...	279,4	42,7	...	315,5	9,1	6

Slip Torque Nm		CPLG SIZE	Maximum Bore with Recommended Keys ▼		Allow Speed rpm
Min	Max		T41 Hub mm	T Hub mm	
4,75	38,0	20T41	24	28	3600
5,65	15,8	30T41-2	32	35	3600
12,4	99,4	30T41	32	35	3600
6,78	26,0	40T41-2	35	43	3600
20,9	167	40T41	35	43	3600
9,04	41,8	50T41-2	45	50	3600
33,9	271	50T41	45	50	3600
11,3	73,4	60T41-2	50	56	3600
58,8	470	60T41	50	56	3600
13,6	108	70T41-2	60	67	3600
87,0	696	70T41	60	67	3600
44,1	192	80T41-2	70	80	2800
153	1 220	80T41	70	80	2800
74,6	316	90T41-2	85	95	2500
254	2 034	90T41	85	95	2500
136	576	100T41-2	100	110	2100
463	3 706	100T41	100	110	2100
203	859	110T41-2	110	120	1850
689	5 514	110T41	110	120	1850
294	1 288	120T41-2	120	140	1750
1 028	8 225	120T41	120	140	1750
429	1 830	130T41-2	145	170	1450
1 469	11 750	130T41	145	170	1450
610	2 599	140T41-2	180	200	1300
2 079	16 631	140T41	180	200	1300
2 938	23 501	150T41	190	215	1100
4 067	32 540	160T41	225	240	950
5 536	44 290	170T41	250	280	870
7 570	60 560	180T41	290	300	760
10 168	81 349	190T41	320	335	720
13 558	108 466	200T41	340	360	670

★ Refer to Page 5 for General Information and Reference Notes. Use a coupling guard that will permit air to circulate and cool the coupling. Gap is 3 mm for Sizes 1020T thru 1090T; 5 mm for Sizes 1100T & 1110T and 6 mm for Sizes 1120T thru 1200T.

♦ Weights are for couplings with Dimension C and W length hubs.

* Dimension shown is for Type T41. Type T41-2=88,9 mm.

▲ To remove cover without disturbing torque setting, allow M clearance.

♣ With new friction segments.

▼ Refer to Tables 15 & 17 for maximum bores with square or rectangular keys.

Types T44 & T44-2

Controlled Torque Clutches/Dimensions — Millimeters

Figure 1 — Sprocket Mounted (not included) – See Sprocket Selections Table 8, Page 20

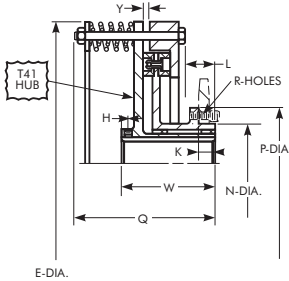
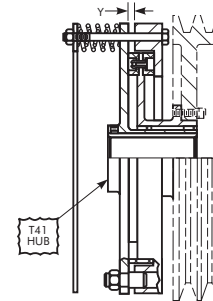

Figure 2 — Sheave Mounted (not included) – See Minimum Sheave Selections Table 9, Page 20.



SIZE ★	Cplg Wt ♦ w/o Bore-kg		DIMENSIONS—MILLIMETERS											Max Chain Size	
			E	H	K	L	N +0,000 -0,025	P	Q	R			W		Y ▼
										Size (UNC - in)	No.	Bolt Circle Dia			
20T	5,26	...	177,8	5,6	19,8	25,4	44,4	61,0	97,5	10-24	4	53,3	79,2	5,1	40
30T	6,49	6,49	201,7	5,6	18,5	25,4	57,2	76,2	104,1	10-24	6	66,0	79,2	5,1	50
40T	8,57	8,35	231,6	5,6	13,5	22,4	66,7	91,4	113,3	.250-20	6	78,7	79,2	5,1	60
50T	13,3	12,9	270,3	5,6	19,0	30,5	76,2	106,7	121,4	.312-18	6	91,4	87,4	5,1	80
60T	16,0	15,3	301,2	8,1	20,1	34,5	88,9	124,5	131,6	.375-16	6	106,7	96,5	5,1	100
70T	20,5	19,6	323,6	8,1	24,6	39,1	101,6	137,2	150,4	.375-16	8	119,4	103,6	5,1	100
80T	28,6	27,4	361,7	8,1	30,7	49,8	120,6	160,0	161,0	.438-14	8	139,7	114,3	5,1	140
90T	44,2	42,0	413,5	8,1	34,3	56,4	139,7	185,4	194,6	.500-13	8	162,6	128,5	5,1	160
100T	75,7	71,2	491,2	...	32,3	58,9	158,8	215,9	213,4	.625-11	8	185,4	143,8	5,3	180
110T	105	98,4	543,1	...	37,6	64,0	171,4	238,8	231,1	.750-10	8	203,2	156,5	9,1	180
120T	131	122	590,3	...	54,9	89,9	193,7	261,6	278,9	.750-10	10	226,1	185,4	9,1	200
130T	205	194	683,8	...	54,9	85,9	235,0	302,3	292,6	.750-10	12	266,7	192,5	9,1	200
140T	289	273	766,6	...	54,9	82,3	279,4	348,0	301,8	.750-10	14	312,4	198,6	8,9	200

★ Refer to Page 5 for General Information and Reference Notes.
 ♦ Weights are for couplings with Dimension W length hubs.
 ▼ With new friction segments.

TABLE 9 — T44 Slip Torques, Bores & Speeds

Slip Torque Nm		CLUTCH SIZE	Max Bore with Recommended Keys *	Allow Speed rpm
Min	Max			
4,75	38,0	20T44	24	3600
5,65	15,8	30T44-2	32	3600
12,4	99,4	30T44		
6,78	26,0	40T44-2	35	3600
20,9	167	40T44		
9,04	41,8	50T44-2	45	3600
33,9	271	50T44		
11,3	73,4	60T44-2	50	3600
58,8	470	60T44		
13,6	108	70T44-2	60	3600
87,0	696	70T44		
44,1	192	80T44-2	70	2800
153	1 220	80T44		
74,6	316	90T44-2	85	2500
254	2 034	90T44		
136	576	100T44-2	100	2100
463	3 706	100T44		
203	859	110T44-2	110	1850
689	5 514	110T44		
294	1 288	120T44-2	120	1750
1 028	8 225	120T44		
429	1 830	130T44-2	145	1450
1 469	11 750	130T44		
610	2 599	140T44-2	180	1300
2 079	16 631	140T44		

* Refer to Table 15 for maximum bores with square or rectangular keys.

TABLE 10 — Sprocket Selections ▲ (Minimum Number of Teeth) – (See Fig. 1)

CHAIN SIZE	CLUTCH SIZE												
	1020	1030	1040	1050	1060	1070	1080	1090	1100	1110	1120	1130	1140
35	24	29
40	19	23	27	30
50	...	19	22	25	29	31
60	19	22	24	26	30
80	17	19	21	24	27	31
100	16	17	20	22	25	27	30
120	17	19	22	24	25	29	...
140	15	17	19	21	22	25	28
160	15	17	19	20	23	25
180	16	17	18	20	23
200	17	19	21	21

▲ Based on minimum clearance for sprocket chain over "P" diameter.

TABLE 11 — Minimum Sheave Selections ♣ (See Fig. 2)

CPLG SIZE	BELT TYPE							
	Outside Diameter – mm				Pitch Diameter – mm			
	3V	5V	8V	A	B	C	D	E
20T	78,7	180,3	317,5	79,5	137,2	228,6	330,2	533,4
30T	94,0	180,3	317,5	94,7	137,2	228,6	330,2	533,4
40T	109,2	180,3	317,5	110,0	137,2	228,6	330,2	533,4
50T	124,5	180,3	317,5	125,2	137,2	228,6	330,2	533,4
60T	142,2	180,3	317,5	143,0	145,0	228,6	330,2	533,4
70T	154,9	180,3	317,5	155,7	157,7	228,6	330,2	533,4
80T	177,8	190,5	317,5	178,6	180,6	228,6	330,2	533,4
90T	203,2	215,9	317,5	204,0	206,0	228,6	330,2	533,4
100T	233,7	246,4	317,5	234,4	236,5	228,6	330,2	533,4
110T	256,5	269,2	317,5	257,3	259,3	268,2	330,2	533,4
120T	279,4	292,1	317,5	280,2	282,2	291,1	330,2	533,4
130T	320,0	332,7	353,1	320,8	322,8	331,7	340,4	533,4
140T	365,8	378,5	398,8	366,5	368,6	377,4	386,1	533,4

♣ Based on mounting flange restrictions.

Types T45 Piloted Controlled Torque Assemblies

A T45 coupling is a hybrid T41/T50 assembly. It provides the shock dampening of a Steelflex grid coupling in a piloted design for floating shafts with a controlled torque feature for overload protection.

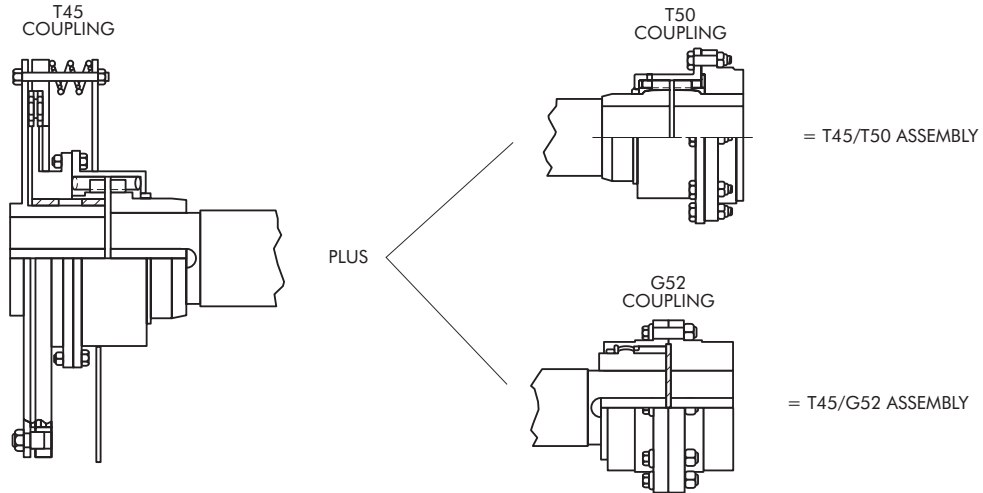

Types T42 Piloted Controlled Torque Assemblies

A T42 coupling is also a hybrid. It is a T41 controlled torque assembly mated to a standard flex half gear coupling. This arrangement provides for high torques and a torsionally stiffer assembly with overload protection.

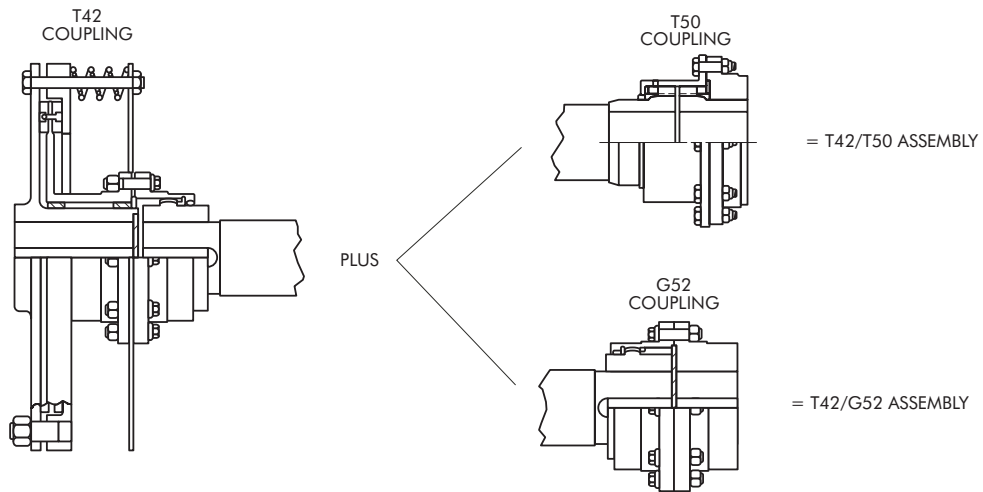

Either the T45 or T42 coupling can be used with a T50 or G52 coupling on the opposite end of the floating shaft to achieve different operational characteristics or preferences for grid or gear couplings.

T42 Flex Half Selection

T42 Control Coupling Size	G52 Flex Half Coupling Size
1030T42	1010G
1040T42	1010G
1050T42	1010G
1060T42	1015G
1070T42	1015G
1080T42	1020G
1090T42	1025G
1100T42	1030G

T42 Flex Half Selection

T42 Control Coupling Size	G52 Flex Half Coupling Size
1110T42	1030G
1120T42	1035G
1130T42	1040G
1140T42	1050G
1150T42	1050G
1160T42	1060G
1170T42	1070G

Optional Automatic Proximity Sensor Cutout Switch

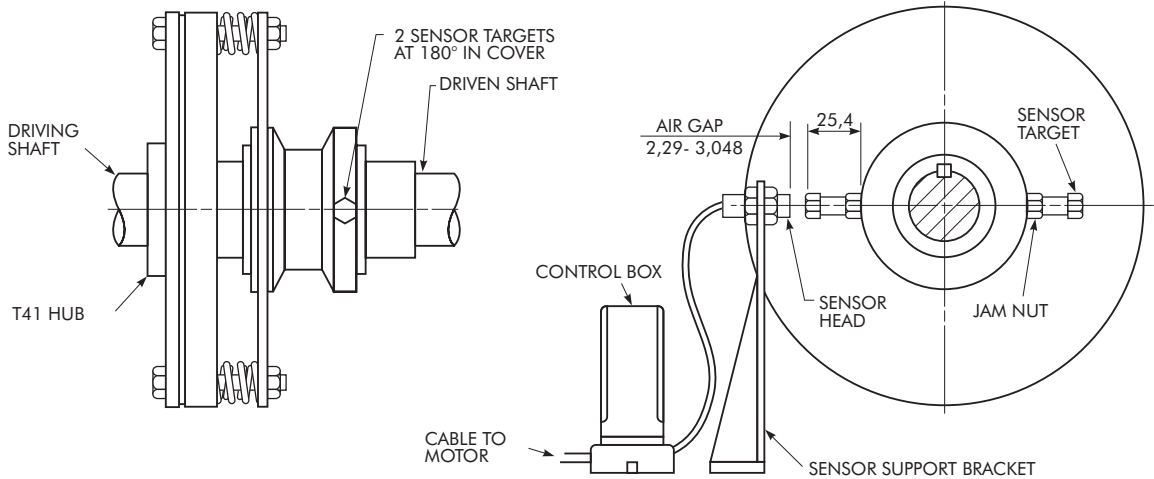

An automatic proximity cutout switch in the motor starter control circuit of controlled torque coupling or clutch application is recommended for protection of connected equipment and coupling or clutch where damaging thermal buildup could develop. Refer to Slip Torque Performance Charts on Pages 24 through 27 to determine if an automatic proximity sensor cutout switch is required.

The proximity cutout switch speed control is adjustable at the control box. It is set at a required cutout speed and continually compares the actual speed of the driven shaft with the set cutout speed. The control box can be mounted in an approximate space of 76,2 millimeters wide by 76,2 millimeters deep by 127,0 millimeters high.

During overload, the coupling or clutch slips at a predetermined speed. When the driven shaft speed drops below the cutout switch speed setting, it opens the motor circuit and the drag load stops the motor shaft.

When the underspeed cutout switch is wired for automatic reset, the drive is immediately ready for service (after overload is removed) without resetting the circuit at any point. To restart the drive, just press either the main or remote control start button. The motor will not maintain normal operation if the overload has not been removed because the motor contractor circuit will reopen as soon as the start button is released.

The customer may incorporate a warning light or an alarm to the circuit to signal the operator of an overload or shutdown condition.

Refer to Service Manual 428-440 for complete details.

Overhanging Hubs

When the distance between shaft ends is greater than the Coupling gap or when the coupling or clutch hub length is greater than the usable shaft length, overhang one or both hubs. For Type T41, if this results in less than one shaft diameter of hub engagement, check key stresses or use a semi-standard long T hub listed in Table 23, Page 42 or submit application details to Falk.

CAUTION: The effect of open keyways on coupling or clutch balance should always be considered.

Dimension Y must be equal to or greater than dimension X for clearance fits, or greater than Dimension X times .75 for interference fits.

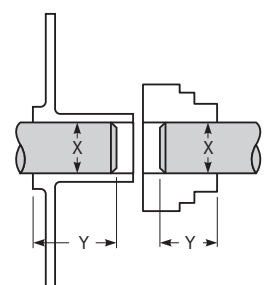

Slip Torque Performance Charts

The following charts are for LT, T41, T41-2, T44 and T44-2 couplings or clutches. The coupling or clutch slip torque setting and operating speed determine the length of time a coupling or clutch can slip without exceeding its thermal capacity. An automatic cutout switch (see Page 21) is **REQUIRED** on applications as indicated in the upper right of the charts (Footnote 1) and is recommended on applications where "minutes of slip and non-slip" are exceeded.

CAUTION: Thermal conditions in the slip torque performance charts apply only when the controlled torque hub is mounted on the driving shaft. When the controlled torque hub is mounted on the driven shaft reduce the slip time by 50%.

During slip, heat is generated at the friction lining surfaces. The following charts specify the thermal capacities. When the torque (slip torque at the slip speed — not motor horsepower) being

dissipated during a slip period exceeds the thermal capacity of the coupling or clutch, the following conditions will result:

1. Lining wear will change the coefficient of friction and slip torque setting.
2. Excessive sleeve bearing wear.
3. Warping of controlled torque hub flange and drive plate flange.
4. Heavy smoke and possibly fire.
5. Complete coupling or clutch failure.

The limits specified in these charts must be adhered to for proper operation of controlled torque couplings or clutches in overload systems. Refer to the Factory all applications requiring operation beyond the coupling or clutch thermal capacity.

SIZE 20T41 & T44

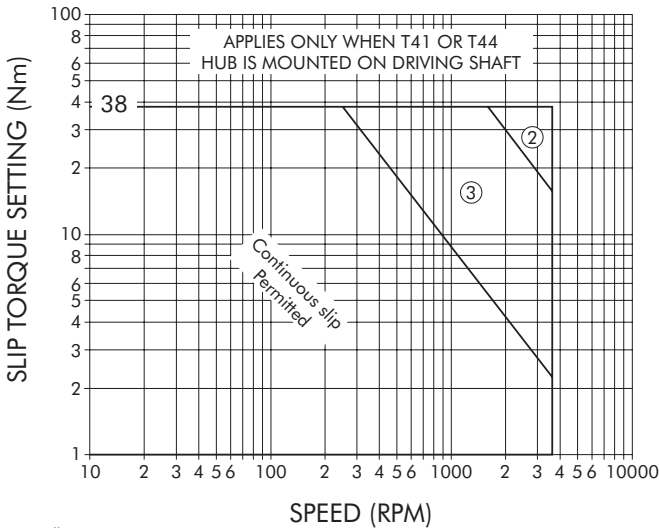

1 - 17 seconds slip permitted if followed by 6 minutes non-slip
 2 - 20 seconds slip permitted if followed by 6 minutes non-slip
 3 - 34 seconds slip permitted if followed by 6 minutes non-slip

SIZE 30T41 & T44

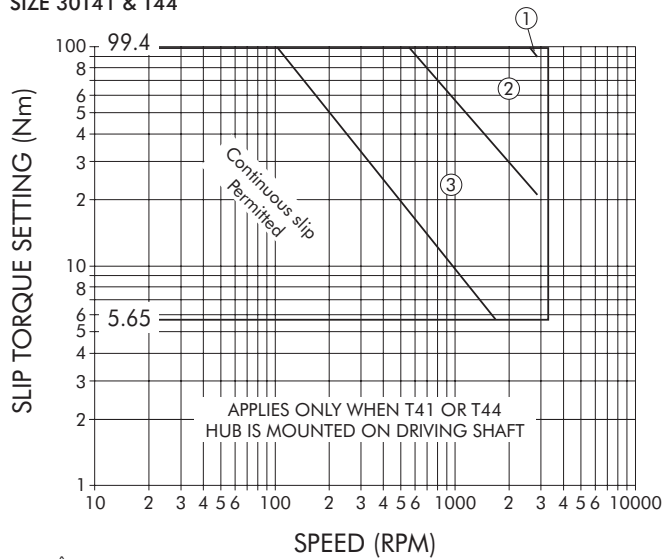

1 - Automatic cutout switch required
 2 - 20 seconds slip permitted if followed by 7 minutes non-slip
 3 - 40 seconds slip permitted if followed by 7 minutes non-slip

SIZE 40T41 & T44

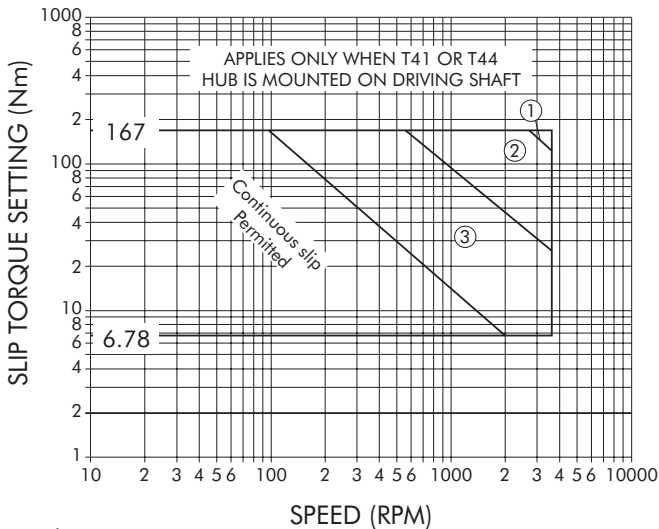

1 - Automatic cutout switch required
 1 - 23 seconds slip permitted if followed by 7.5 minutes non-slip
 2 - 45 seconds slip permitted if followed by 7.5 minutes non-slip

SIZE 50T41 & T44

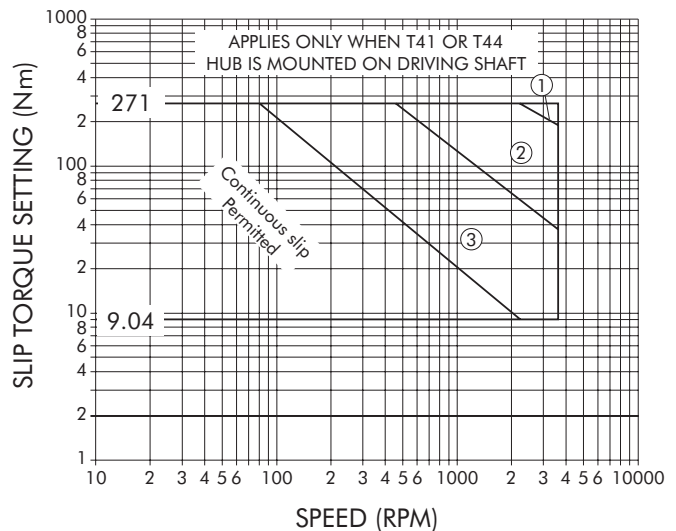

1 - Automatic cutout switch required
 1 - 27 seconds slip permitted if followed by 9 minutes non-slip
 2 - 54 seconds slip permitted if followed by 9 minutes non-slip

SIZE 60T41 & T44

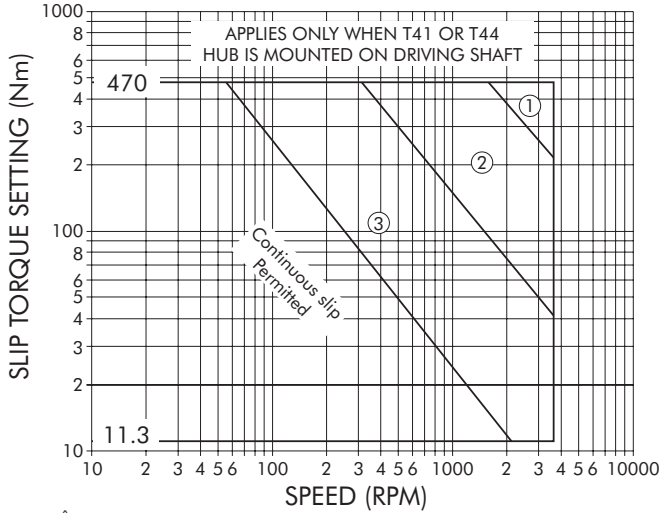

⌠ - Automatic cutout switch required
 Ⓘ - 30 seconds slip permitted if followed by 10 minutes non-slip
 Ⓓ - 60 seconds slip permitted if followed by 10 minutes non-slip

SIZE 70T41 & T44

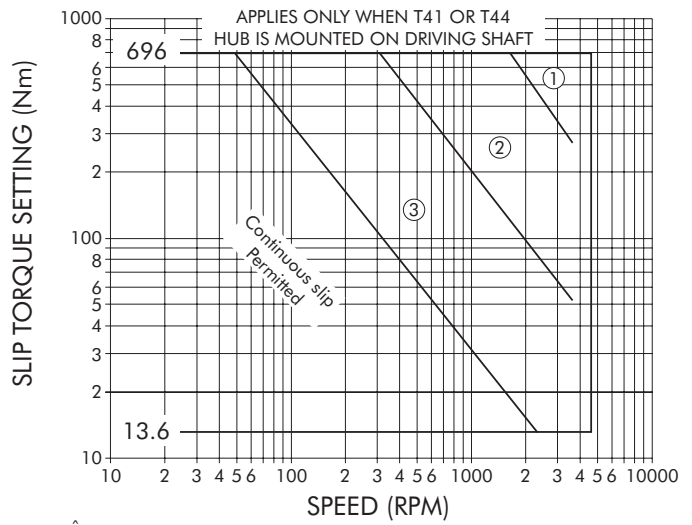

⌠ - Automatic cutout switch required
 Ⓘ - 33 seconds slip permitted if followed by 11 minutes non-slip
 Ⓓ - 66 seconds slip permitted if followed by 11 minutes non-slip

SIZE 80T41 & T44

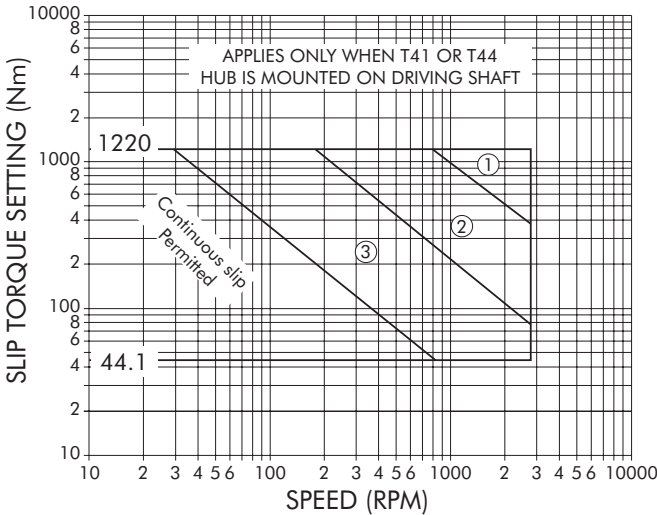

⌠ - Automatic cutout switch required
 Ⓘ - 36 seconds slip permitted if followed by 12 minutes non-slip
 Ⓓ - 72 seconds slip permitted if followed by 12 minutes non-slip

SIZE 90T41 & T44

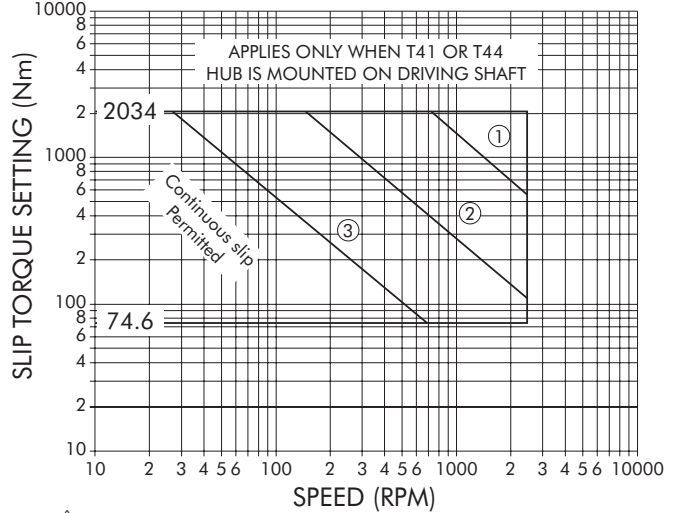

⌠ - Automatic cutout switch required
 Ⓘ - 40 seconds slip permitted if followed by 14 minutes non-slip
 Ⓓ - 80 seconds slip permitted if followed by 14 minutes non-slip

SIZE 100T41 & T44

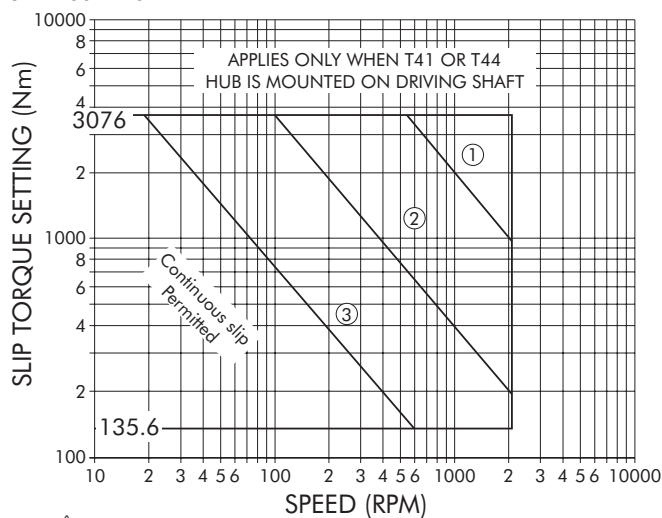

⌠ - Automatic cutout switch required
 Ⓘ - 48 seconds slip permitted if followed by 16 minutes non-slip
 Ⓓ - 96 seconds slip permitted if followed by 16 minutes non-slip

SIZE 110T41 & T44

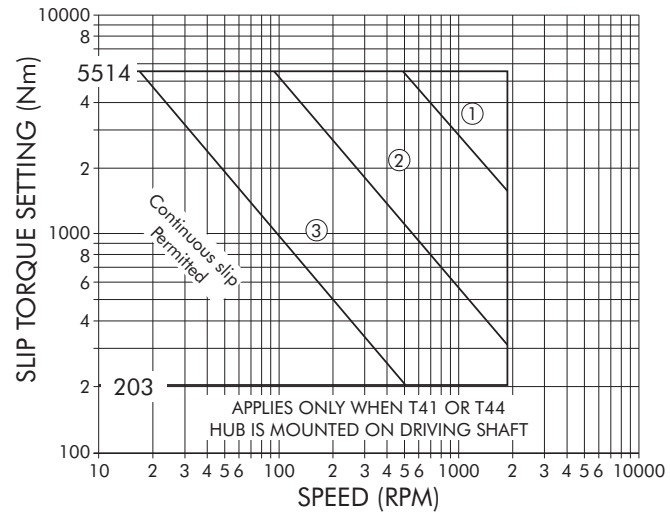

⌠ - Automatic cutout switch required
 Ⓘ - 55 seconds slip permitted if followed by 18 minutes non-slip
 Ⓓ - 110 seconds slip permitted if followed by 18 minutes non-slip

SIZE 120T41 & T44

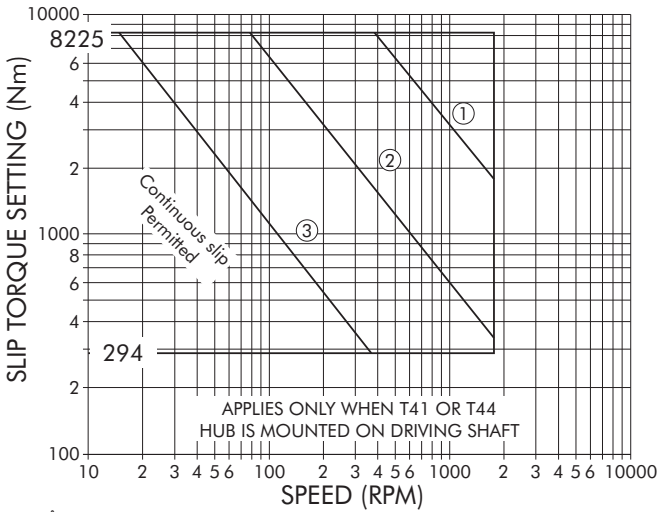

- ⌘ - Automatic cutout switch required
- 1 - 60 seconds slip permitted if followed by 20 minutes non-slip
- ⌀ - 120 seconds slip permitted if followed by 20 minutes non-slip

SIZE 130T41 & T44

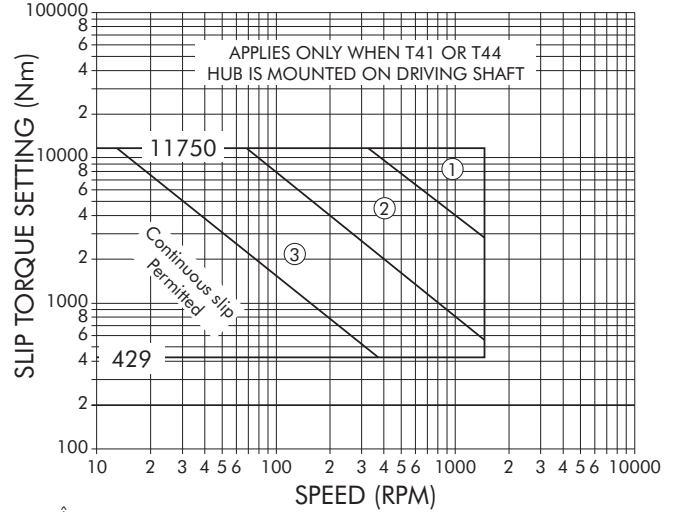

- ⌘ - Automatic cutout switch required
- 1 - 70 seconds slip permitted if followed by 23 minutes non-slip
- ⌀ - 140 seconds slip permitted if followed by 23 minutes non-slip

SIZE 140T41 & T44

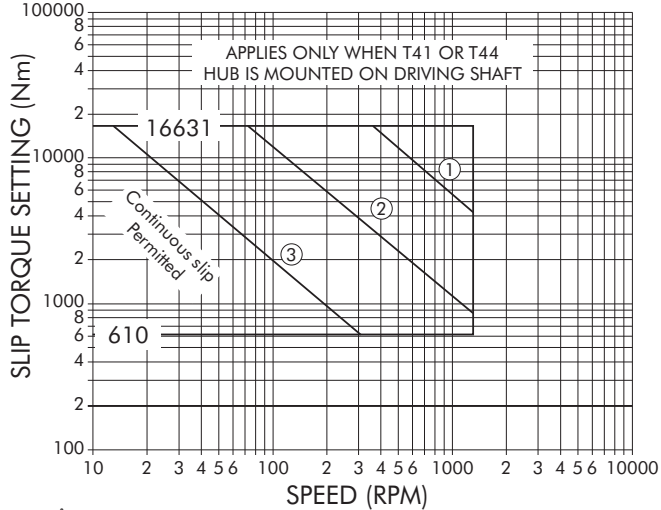

- ⌘ - Automatic cutout switch required
- 1 - 80 seconds slip permitted if followed by 26 minutes non-slip
- ⌀ - 160 seconds slip permitted if followed by 26 minutes non-slip

SIZE 150T41

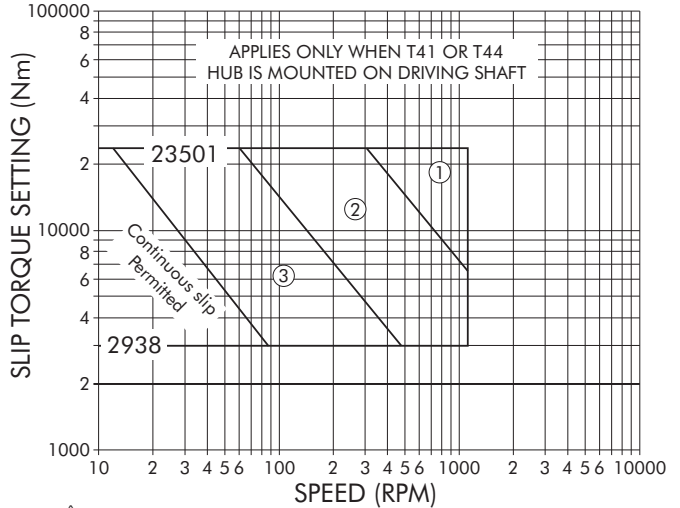

- ⌘ - Automatic cutout switch required
- 1 - 92 seconds slip permitted if followed by 31 minutes non-slip
- ⌀ - 184 seconds slip permitted if followed by 31 minutes non-slip

SIZE 160T41

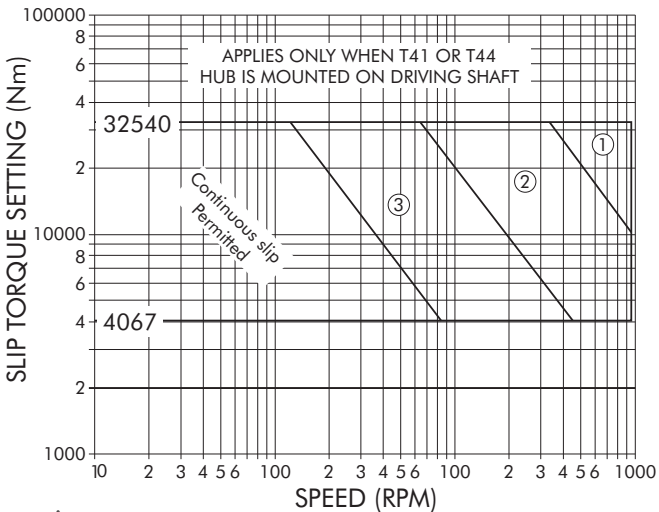

- ⌘ - Automatic cutout switch required
- 1 - 106 seconds slip permitted if followed by 35 minutes non-slip
- ⌀ - 212 seconds slip permitted if followed by 35 minutes non-slip

SIZE 170T41

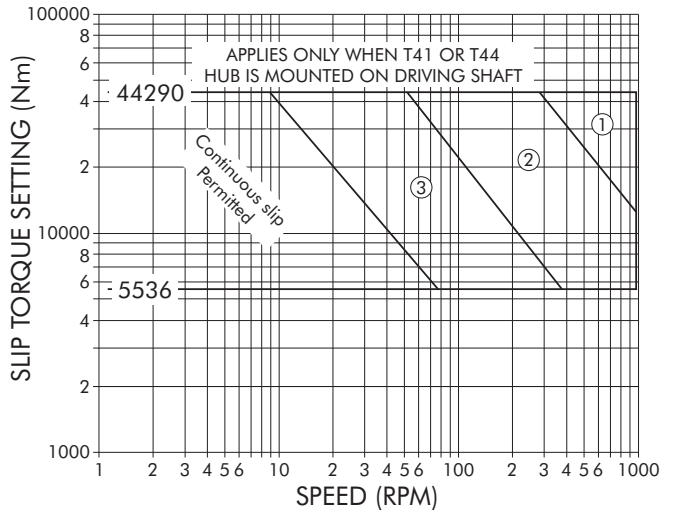

- ⌘ - Automatic cutout switch required
- 1 - 110 seconds slip permitted if followed by 37 minutes non-slip
- ⌀ - 220 seconds slip permitted if followed by 37 minutes non-slip

SIZE 180T41

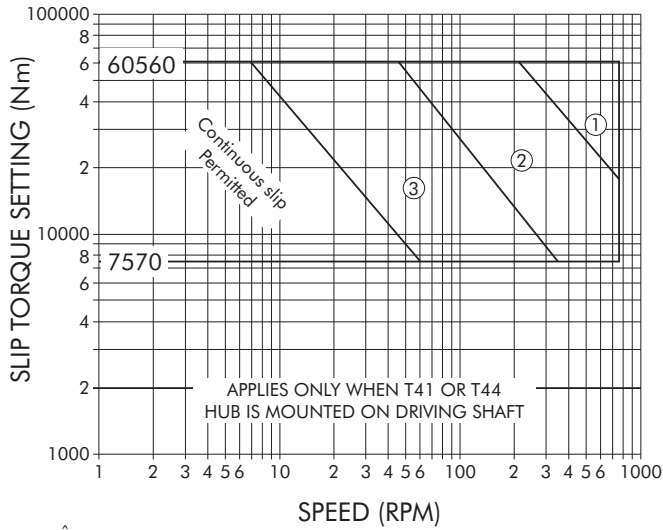

- ⌆ - Automatic cutout switch required
- ⌈ - 122 seconds slip permitted if followed by 40 minutes non-slip
- Ⓓ - 224 seconds slip permitted if followed by 40 minutes non-slip

SIZE 190T41

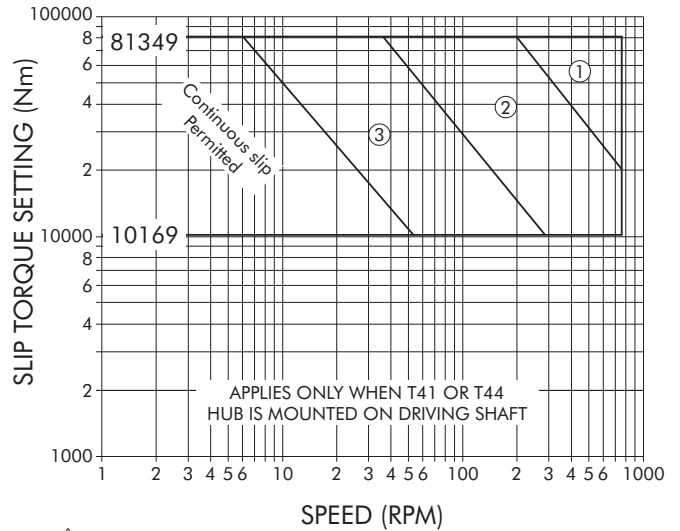

- ⌆ - Automatic cutout switch required
- ⌈ - 133 seconds slip permitted if followed by 44 minutes non-slip
- Ⓓ - 266 seconds slip permitted if followed by 44 minutes non-slip

SIZE 200T41

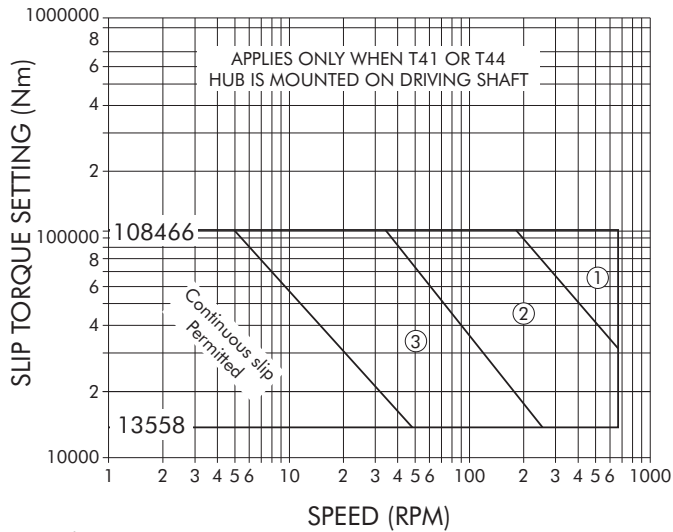

- ⌆ - Automatic cutout switch required
- ⌈ - 150 seconds slip permitted if followed by 50 minutes non-slip
- Ⓓ - 300 seconds slip permitted if followed by 50 minutes non-slip

Type T50

Floating Shaft/Dimensions — Millimeters

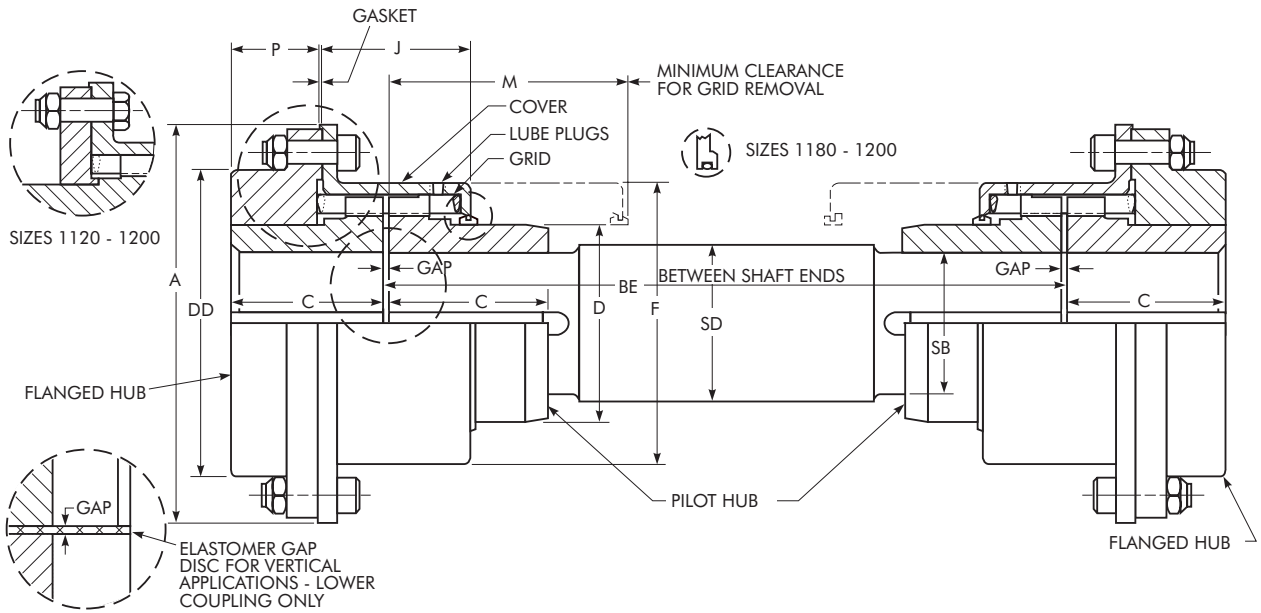

SIZE ★	Torque Rating Nm †	Max Bore (Flanged Hub) mm ●	Min Bore mm ■	Pilot Hub Bore mm	Wt Per Cplg No Bore-kg	Wt Added Per mm of length of "SD" Diameter Between Hubs	Lube Wt Per Cplg-kg	DIMENSIONS — MILLIMETERS											
								A	BE Min	C	D	DD	F	J	M	P	SB	SD	Gap
1030T	149	35	13	27,0	3,90	0,00498	0,0408	115,9	162	47,6	49,2	83,7	80,8	50,3	77,7	26,8	27,0	28,6	3
1050T	435	50	13	36,5	8,84	0,00893	0,0680	157,5	195	60,3	66,7	105,2	104,8	59,2	94,0	36,2	36,5	38,1	3
1070T	994	67	20	49,2	15,6	0,016	0,113	182,9	213	76,2	87,3	126,5	129,0	65,9	103,1	49,8	49,2	50,8	3
1080T	2 050	80	27	61,9	26,4	0,025	0,172	218,4	275	88,9	104,8	154,9	156,2	85,9	134,1	52,1	61,9	63,5	3
1090T	3 730	95	27	74,6	37,2	0,036	0,254	244,9	294	98,4	123,8	180,3	175,8	92,2	143,8	58,5	74,6	76,2	3
1100T	6 280	110	42	92,1	62,8	0,056	0,426	286,0	372	120,6	142,1	211,3	208,3	117,3	181,4	69,3	92,1	95,2	5
1110T	9 320	120	42	101,6	83,6	0,067	0,508	324,1	391	127,0	160,3	245,4	228,6	122,2	190,5	73,9	101,6	104,8	5
1120T	13 700	140	61	117,5	97,9	0,090	0,735	327,2	453	149,2	179,4	179,3	257,0	146,3	220,0	83,6	117,5	120,6	6
1130T	19 900	170	67	133,4	140	0,115	0,907	365,3	463	161,9	217,5	217,4	295,1	149,5	225,0	94,8	133,4	136,5	6
1140T	28 600	200	67	142,9	210	0,131	1,13	419,1	482	184,2	254,0	254,0	335,8	155,8	234,7	113,8	142,9	146,0	6
1150T	39 800	215	108	161,9	277	0,168	1,95	477,5	549	182,9	271,4	269,2	391,2	177,4	268,2	101,7	161,9	165,1	6
1160T	55 900	240	121	200,0	381	0,254	2,81	548,6	587	198,1	304,8	304,8	442,0	189,4	287,0	111,9	200,0	203,2	6
1170T	74 600	280	134	200,0	519	0,254	3,49	604,5	622	215,9	355,6	355,6	494,3	201,0	304,8	124,6	200,0	203,2	6
1180T	103 000	300	153	225,4	718	0,322	3,76	665,5	673	238,8	393,7	393,7	556,3	226,9	330,2	141,4	225,4	228,6	6
1190T	137 000	335	153	250,8	898	0,397	4,40	708,7	711	259,1	436,9	436,9	599,4	241,7	349,5	157,6	250,8	254,0	6
1200T	186 000	360	178	276,2	1 205	0,480	5,62	782,3	744	279,4	497,8	497,8	622,9	251,8	365,8	172,8	276,2	279,4	6

★ Refer to Page 5 for General Information and Reference Note.

Type T50

Floating Shaft/Selections

Introduction — Floating shaft diameters have been preselected to transmit the coupling torque and need only to be checked for allowable speed.

Construction — Standard shafts are solid, AISI 1018 or 1020 cold rolled steel. Also available is an optional solid, AISI 1018, fully turned, hot rolled steel shaft.

Determine the Allowable Shaft Length

- Select the coupling size per Pages 9 and 28.
- From Page 28, determine shaft diameter (Dimension SD) for the coupling selected.
- From the table below, locate the floating shaft diameter (Dimension SD) determined in Step B.

D. Determine the allowable shaft length for the required operating speed.

For Speeds under 540 rpm — Read the maximum allowable shaft length to the left of the required shaft diameter.

For Speeds over 540 rpm — Trace right from the shaft diameter determined along the diagonal line to the point of intersection with the required vertical operating speed line. Trace right along the horizontal line to the right and read the maximum allowable shaft length.

E. Determine if shaft requires balancing. Locate point where operating speed and floating shaft length cross. Balance is required when point is located to the right of bold line.

F. If a longer shaft is required, reduce the operating speed if practical, or select the next larger size coupling.
 Note: For such conditions, the use of a tubular shaft design should be considered, refer application details to the local Rexnord Representative.

TABLE 12 — Floating Shaft Selections

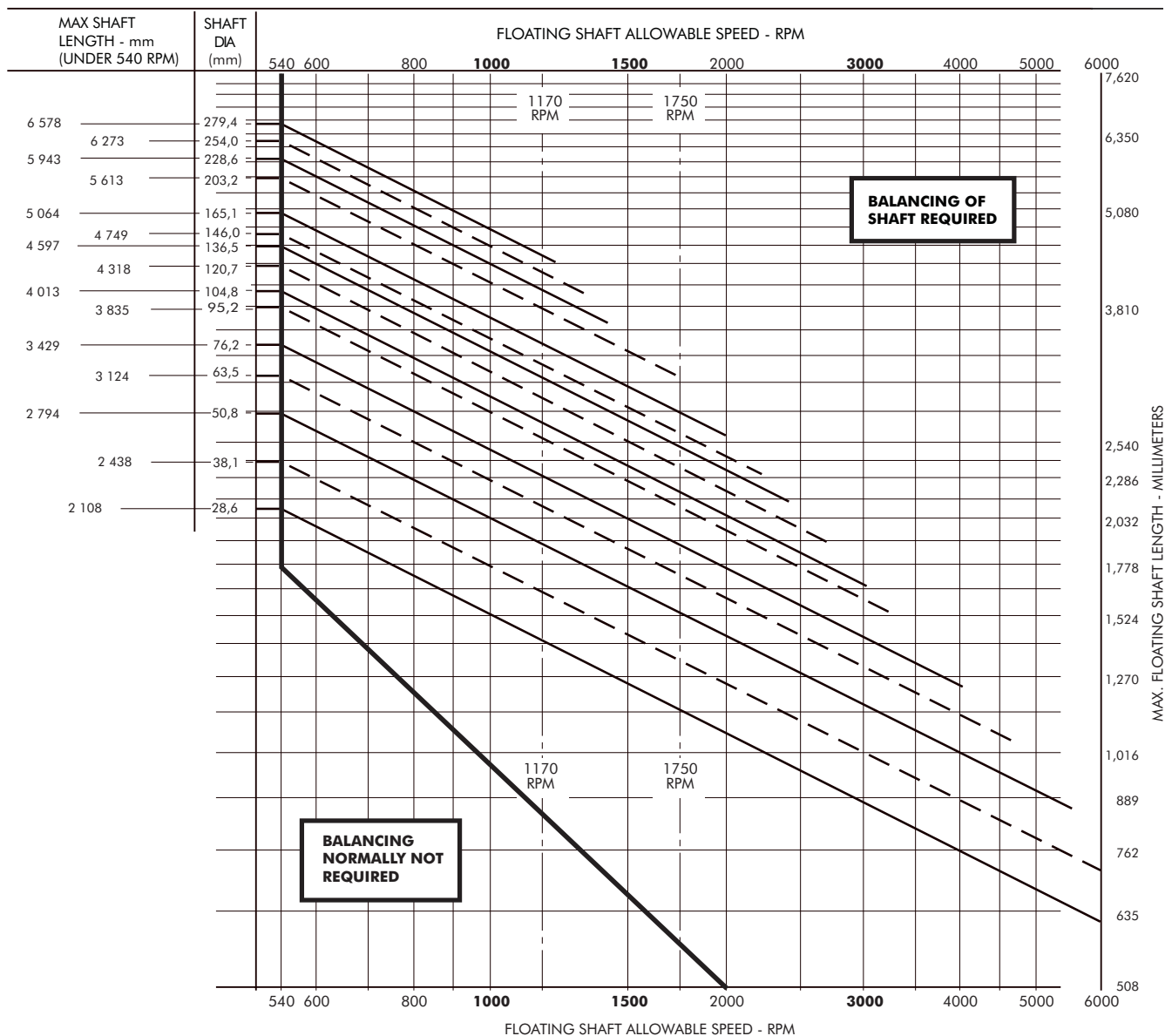

Caliper Disc Brake System

Rexnord will supply Type T63 Disc Couplings for use with calipers and power systems by others, or a fail-safe Caliper Disc Brake System. The system is comprised of a Falk Steelflex Coupling, caliper disc brake, basic hydraulic circuits and components. These systems are designed to be used as parking or holding brakes, or limited usage dynamic stopping brakes.

Rexnord will purchase for resale the caliper disc brakes and hydraulic components preassembled in a power package.

Rexnord can assemble or mount the T63 coupling, disc brake, and hydraulic system when these components are ordered in conjunction with Falk gear drives.

Capabilities

The Falk Steelflex Disc Brake Coupling with Caliper Brake System has an assigned coupling brake rating range of 11 to 16 938 Nm.

Description of the Disc Brake Coupling and Caliper System

The system consists of a standard T63 coupling using disc diameter and thickness compatible with one caliper brake manufacturer. Both MICO-Minnesota Automotive Inc., and Goodyear Aerospace Corporation caliper disc brakes are used on Sizes 50T63 through 120T63 and 130T63, respectively. Both caliper manufacturers use different mounting hole patterns and bracket styles. MICO and Goodyear caliper disc brakes require hydraulic pressure.

Caliper Disc Brakes

The caliper disc brake is spring loaded to apply the brake. Hydraulic pressure is required to release or "hold off" the brake. Normal operation is to have the brake pressurized in the released position with the hydraulic system running. Conditions such as an electric power or pressure system failure, which reduces the system pressure below the release pressure of the brake, will initiate a brake application.

Hydraulic Brake System

The system consist of an oil tank, filter, gear pump and electric motor, relief valve, check valve, solenoid direction control valve, pressure gauge, duplex pressure switch, 1.52 meter hydraulic hose with connections and caliper disc brake.

Operation

The hydraulic brake system is actuated by turning on its electric motor. The motor drives a gear pump which produces a flow of oil between pump and solenoid directional control valve. When the solenoid directional control valve is energized, oil pressure rises in the caliper brake compressing the belleville springs to apply the brake.

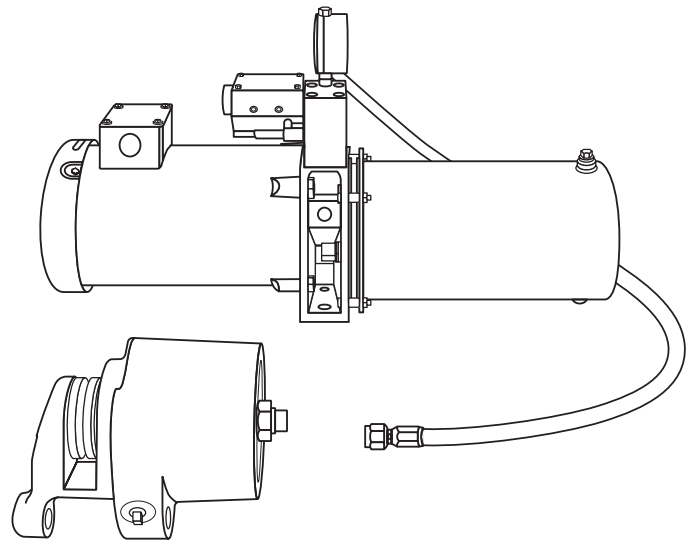
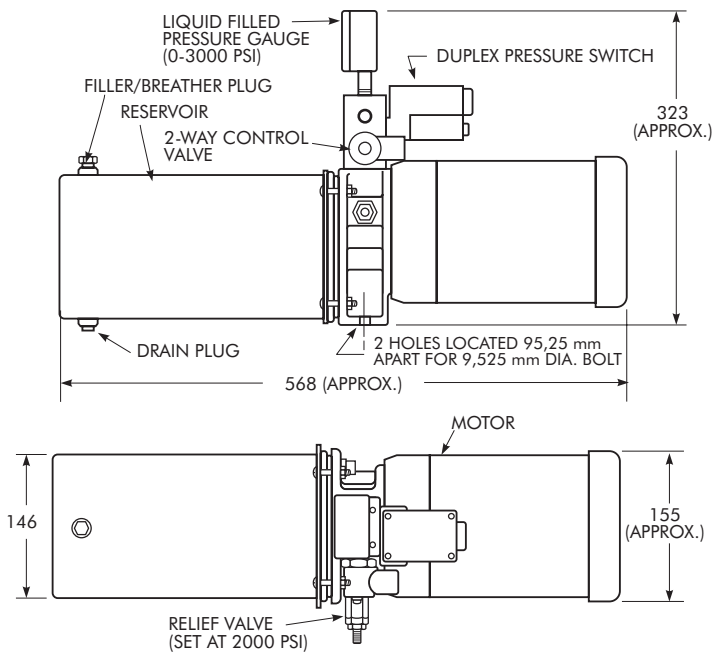

Type T63

Disc Brake/Dimensions — Millimeters

NOTE: Falk Type T63 couplings or brake assemblies are not approved as a primary brake for applications used to lift or transport people such as elevators, escalators, hoists, lifts, etc.

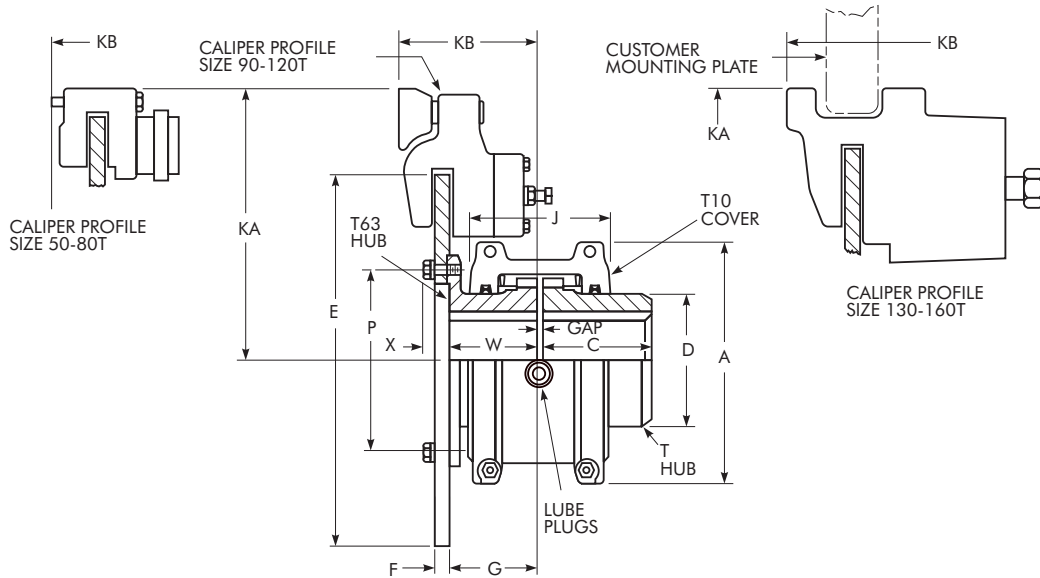

SIZE ★	Cplg Brake Rating Nm	Brake Disc Dia x Thickness (E x F) *	Allow Speed rpm ‡	Max Bore mm ◆	Min Bore mm ■	Cplg Wt With No Bore & No Disc-kg	Lube Wt kg	DIMENSIONS — MILLIMETERS									SIZE ★
								A	C	D	G	J	P	W	X	Gap	
20T	11	203 x 6,4	4500	28	13	2,55	0,03	101,6	47,8	39,6	59,9	66,5	71,4	60,5	11,7	3	20T
30T	35	254 x 6,4	4500	35	13	3,31	0,04	111,3	47,8	49,3	59,9	68,3	79,4	60,5	11,7	3	30T
40T	65	254 x 6,4	4500	43	13	4,26	0,05	117,3	50,8	57,2	59,9	69,9	98,4	60,5	11,7	3	40T
50T	118	254 x 6,4	4150	50	13	6,35	0,07	138,2	60,5	66,5	59,9	79,2	108,0	60,5	13,2	3	50T
60T	209	305 x 6,4	3800	56	20	9,57	0,09	150,9	63,5	76,2	88,6	91,9	125,4	88,1	15,2	3	60T
70T	331	305 x 6,4	3250	67	20	12,3	0,11	162,1	76,2	87,4	88,6	95,3	133,4	88,1	15,2	3	70T
80T	637	305 x 6,4	2850	80	27	19,8	0,17	193,5	88,9	104,6	88,6	115,8	152,4	88,1	18,0	3	80T
90T	1 084	407 x 12,7	2700	95	27	28,4	0,25	212,9	98,6	124,0	87,9	122,2	179,4	88,1	26,9	3	90T
100T	1 897	407 x 12,7	2400	110	42	47,7	0,43	251,0	120,6	142,0	119,1	155,4	215,9	119,1	29,5	5	100T
110T	2 846	458 x 12,7	2250	120	42	64,9	0,51	269,7	127,0	160,3	146,0	161,5	241,3	146,0	29,5	5	110T
120T	4 336	509 x 12,7	2025	140	61	92,1	0,73	307,8	149,4	179,3	150,1	191,5	276,2	149,4	33,0	6	120T
130T	6 098	559 x 12,7	1800	170	67	132	0,91	345,9	162,1	217,4	153,4	195,1	295,3	152,4	35,6	6	130T
140T	8 808	610 x 12,7	1650	200	67	185	1,13	384,0	184,2	254,0	159,8	201,2	330,2	158,8	38,1	6	140T
150T	12 195	763 x 12,7	1500	215	108	253	1,91	453,1	182,9	269,2	179,8	271,3	368,3	182,9	31,5	6	150T
160T	16 938	915 x 12,7	1350	240	121	336	2,81	501,4	198,1	304,8	195,1	278,9	400,0	198,1	31,5	6	160T

★ Refer to Page 5 for General Information and Reference Notes.

◆ Couplings will be furnished for INTERFERENCE FIT without a set screw. Clearance fit and/or hubs with set screws are not recommended. Rexnord standards apply unless other wise specified. Maximum bores listed are based on recommended keys shown in Table 13, Page 36. For other maximum bore-key combinations that can be manufactured to order, refer to Table 15 on Page 37.

* Refer to the Factory for discs with dimensions other than shown.

Type T63

Disc Brake Caliper System/Dimensions — Millimeters

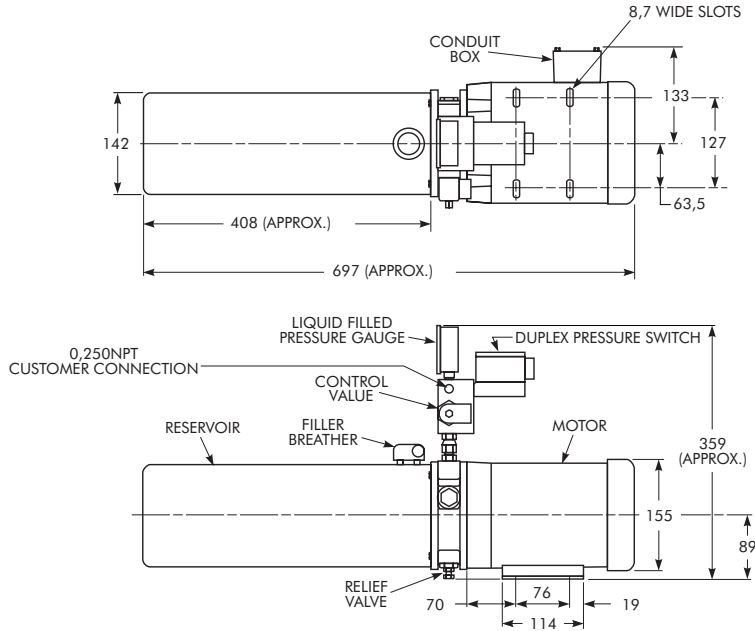

CPLG SIZE	Caliper Brake ▲				DIMENSIONS — MILLIMETERS	
	Brand	Model No. ♦	Torque—Nm		KA	KB ♣
			Min	Max		
20T 30T 40T	These sizes are best activated by Electromagnetic or Pneumatic Caliper Systems					
50T	MICO, Inc	02-515-002	62,3	122	158,0	96,5
60T		02-515-004	157	244	183,4	125,2
70T		02-515-008	474	556	183,4	125,2
80T		02-515-006	631	701	183,4	125,2
90T		02-530-306	772	1,460	292,1	138,7
100T		02-530-628	724	2,480	292,1	169,9
110T		02-530-628	829	2,850	342,9	196,8
120T	02-530-600	1,880	4,460	336,6	200,9	
130T	Meritor	PD1591	2,200	8,260	336,6	216,9
140T		PD1591	2,430	9,100	362,0	223,3
150T		SCL25	4,660	23,300	461,8	245,9
160T		SCL25	5,670	28,400	539,0	260,3

♦ These brakes use hydraulic oil (NOT brake fluid). Any high grade hydraulic oil with viscosities of 150 SSU-350 SSU @ 38°C is suitable.

▲ Maximum torque shown is rating with new pads. Minimum torque shown is rating at point when caliper requires adjustment for pad wear.

♣ dimension KB is to caliper mounting surface for Coupling Sizes 50T thru 120T, and to caliper edge for Coupling Sizes 130T and larger.

Type T70

High Speed/Dimensions — Millimeters

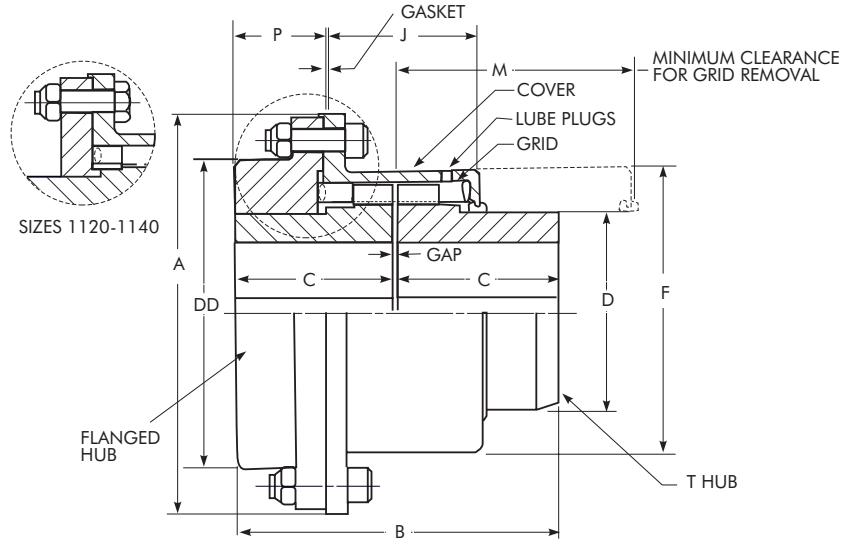

SIZE ★	Torque Rating Nm †	Allow Speed rpm ‡	Max Bore mm ●	Min Bore mm ■	Cplg Wt With No Bore-kg	Lube Wt kg	DIMENSIONS — MILLIMETERS									
							A	B	C	D	DD	F	J	M	P	Gap
1030T	149	10,000	35	13	3,90	0,041	115,8	98,6	47,8	49,3	83,8	80,8	50,3	77,7	26,9	3
1050T	435	9,000	50	13	8,84	0,068	157,5	124,0	60,5	66,5	105,2	104,6	59,2	94,0	36,1	3
1070T	994	8,200	67	20	15,6	0,113	182,9	155,4	76,2	87,4	126,5	129,0	65,0	103,1	49,8	3
1080T	2 050	7,100	80	27	26,4	0,172	218,4	180,8	88,9	104,6	154,9	156,2	85,9	134,1	52,1	3
1090T	3 730	6,000	95	27	37,2	0,254	244,9	200,2	98,6	124,0	180,3	175,8	92,2	143,8	58,4	3
1100T	6 280	4,900	110	42	62,8	0,426	286,0	246,1	120,6	116,6	211,3	208,3	117,3	181,4	69,3	5
1110T	9 320	4,500	120	42	83,6	0,508	324,1	258,8	127,0	160,3	245,4	228,6	122,2	190,5	73,9	5
1120T	13 700	4,000	140	61	97,9	0,735	327,2	304,8	149,4	179,3	179,3	257,0	146,3	220,0	83,6	6
1130T	19 900	3,600	170	67	140	0,907	365,3	330,2	162,1	217,4	217,4	295,1	149,4	225,0	94,7	6
1140T	28 600	3,300	200	67	210	1,13	419,1	374,6	184,2	254,0	254,0	335,8	156,0	234,7	113,8	6

★ Refer to Page 5 for General Information and Reference Notes.

Type T90

Engine Flywheel Adapter/Dimensions — Millimeters

Used primarily to connect the flywheel of an engine to the driven machinery. Adapter plates are designed to accommodate standard SAE J620 bolt patterns. The T90 design provides for higher torque ratings with resulting smaller sizes and lower costs than elastomer coupling designs. The flexible gridmember provides torsional damping in addition to accepting misalignment. Adapter plates are bolted and doweled to the hub to provide a secure joint.

Selection — Determine the proper Steelflex coupling size using the selection method. Check size selected against those shown in table below for the clutch size used on the engine flywheel. If the coupling size is not shown, refer all details to the Factory.

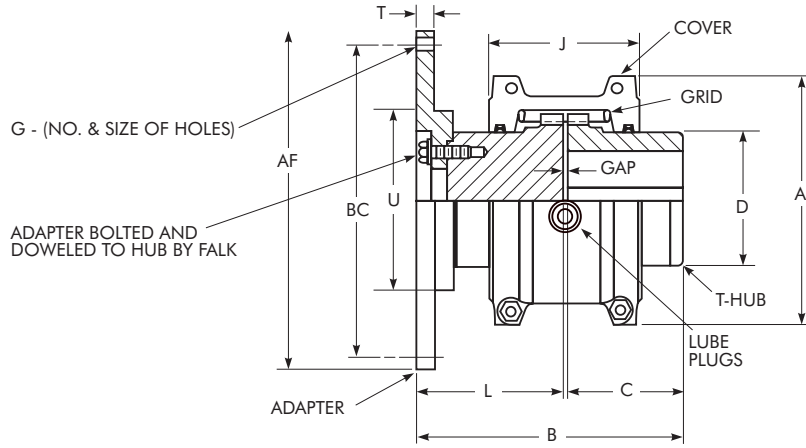

Clutch Dia	Adapter—Inches				CPLG SIZE ★	Assembly Torque Rating † Nm	Allow Speed rpm ‡	Max Bore mm ●	Min Bore mm ■	Cplg Wt No Bore in T Hub kg	WR ²	DIMENSIONS — MILLIMETERS							
	AF +.000 - .005	BC	G	T								A	B	C	D	J	L	U	Gap
6.5	8.500	7.875	6-.344	.375	1050T	395	3600	50	13	8,16	0,025	138,2	141,7	60,5	66,5	79,2	78,0	127,0	3
				.375	1060T	621	3600	56	20	10,4	0,031	150,9	150,9	63,5	76,2	91,9	84,1	139,7	3
				.375	1070T	904	3600	67	20	13,2	0,038	162,1	176,3	76,2	87,4	95,2	96,8	149,4	3
7.5	9.500	8.750	8-.344	.375	1050T	395	3600	50	13	9,07	0,034	138,2	141,7	60,5	66,5	79,2	78,0	127,0	3
				.375	1060T	621	3600	56	20	10,9	0,040	150,9	150,9	63,5	76,2	91,9	84,1	139,7	3
				.375	1070T	904	3600	67	20	13,6	0,047	162,1	176,3	76,2	87,4	95,2	96,8	149,4	3
8	10.375	9.625	6-.406	.375	1050T	395	3600	50	13	9,53	0,044	138,2	141,7	60,5	66,5	79,2	78,0	127,0	3
				.375	1060T	621	3600	56	20	11,8	0,050	150,9	150,9	63,5	76,2	91,9	84,1	139,7	3
				.375	1070T	904	3600	67	20	14,5	0,057	162,1	176,3	76,2	87,4	95,2	96,8	149,4	3
				.500	1080T	1 860	3600	80	27	21,8	0,097	193,5	205,0	88,9	104,6	115,8	112,8	165,1	3
10	12.375	11.625	8-.406	.500	1080T	1 860	3600	80	27	24,0	0,145	193,5	205,0	88,9	104,6	115,8	112,8	165,1	3
11.5	13.875	13.125	8-.406	.500	1090T	3 390	3600	95	27	33,6	0,240	212,9	227,3	98,6	124,0	122,2	125,5	190,5	3
14	18.375	17.250	8-.531	.650	1100T	5 710	2440	110	42	60,3	0,791	251,0	276,9	120,6	142,0	155,4	151,4	212,9	5
				.750	1110T	8 470	2250	120	42	73,5	0,965	269,7	292,1	127,0	160,3	161,5	160,3	231,9	5
16	20.375	19.250	8-.531	.650	1100T	5 710	2440	110	42	65,8	1,097	251,0	276,9	120,6	142,0	155,4	151,4	212,9	5
				.750	1110T	8 470	2250	120	42	79,4	1,319	269,7	292,1	127,0	160,3	161,5	160,3	231,9	5
18	22.500	21.375	6-.656	.750	1110T	5 710	2250	120	42	86,2	1,827	269,7	292,1	127,0	160,3	161,5	160,3	231,9	5
				.750	1120T	12 400	2025	140	61	110	2,096	307,8	341,1	149,4	179,3	191,5	185,4	254,0	6
				.900	1130T	10 100	1800	170	67	150	2,849	345,9	373,1	162,1	217,4	195,1	204,7	292,1	6
21	26.500	27.250	12-.656	.900	1130T	10 100	1800	170	67	168	4,553	345,9	373,1	162,1	217,4	195,1	204,7	298,5	6
				1.000	1140T	26 000	1650	200	67	217	5,738	384,0	419,9	184,2	254,0	201,2	229,4	336,6	6
				1.000	1150T	36 200	1500	215	108	276	7,572	453,1	420,6	182,9	269,2	271,3	231,4	349,3	6
24	28.875	27.250	12-.812	.900	1130T	10 100	1800	170	67	180	5,987	345,9	373,1	162,1	217,4	195,1	204,7	298,5	6
				1.000	1140T	26 000	1650	200	67	230	7,332	384,0	419,9	184,2	254,0	201,2	229,4	336,6	6
				1.000	1150T	36 200	1500	215	108	289	9,174	453,1	420,6	182,9	269,2	271,5	231,4	349,3	6
Machined as Required				1.000	1160T	50 800	1350	240	121	298 ▲	...	501,9	453,4	198,1	304,8	278,4	248,9	393,7	6
				1.250	1170T	67 800	1225	280	134	409 ▲	...	566,9	495,3	215,9	355,6	307,3	273,0	438,2	6

★ See Page 5 for General Information and Reference Notes.
▲ For total coupling weight add [0,101 x (AF² - U²) x T] to value shown.

Type T10/G82

Floating Shaft/Dimensions — Millimeters

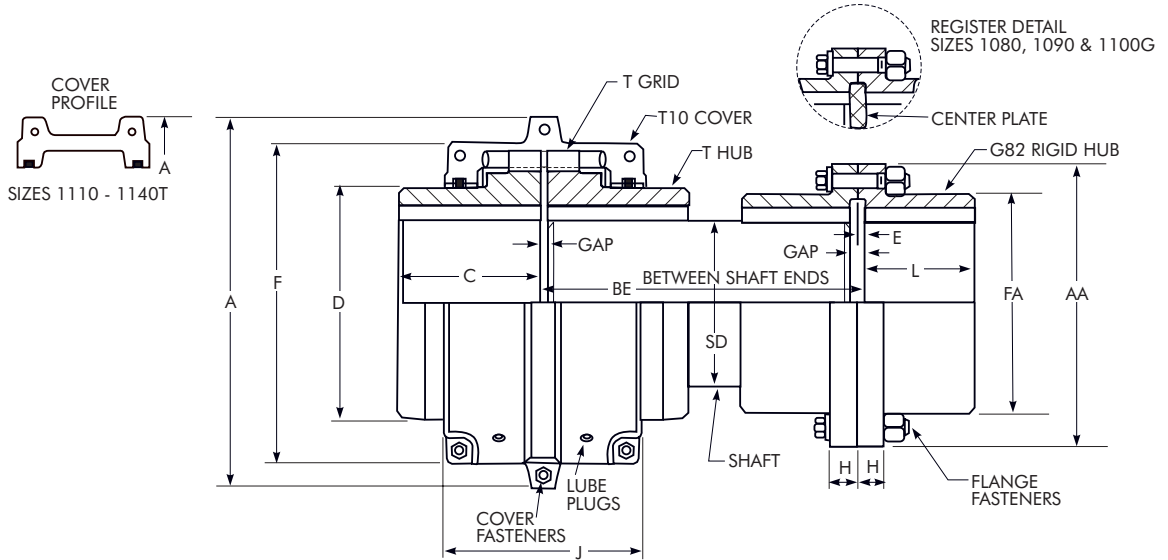

T10 SIZE ★	G82 SIZE ★	Torque Rating Nm †	Allow Speed rpm ‡	Max Bore mm •				Min Bore mm ■				Cplg Wt With No Bore & No Shaft kg	Wt Added Per mm of Length of "SD" Diameter Between Hubs	Lube Wt kg	DIMENSIONS — MILLIMETERS															Flange Fasteners	
				T10 Hub		G82 Hub		T10 Hub		G82 Hub					A	BE		C	D	E	F	H	J	L	AA	FA ♦	SD	Gap		No Per Flange & Grade	Dia In
				T10 Hub	G82 Hub	T10 Hub	G82 Hub	Min	Max	T Hub	G82 Hub																				
1110T	1035G	9 320	2250	120	164	42	51	125	0,0804	0,508	269,7	239,0	304,8	127,0	160,3	2,5	...	28,4	161,5	102,1	279,4	211,3	114,3	5	5	8-Gr 8	.750				
1120T	1040G	13 700	2025	140	196	61	64	183	0,0992	0,735	307,8	279,1	355,6	149,4	179,3	4,1	...	28,4	191,5	115,3	317,5	245,4	127,0	6	8	8-Gr 8	.750				
1130T	1045G	19 900	1800	170	216	67	76	261	0,143	0,907	345,9	307,1	381,0	162,1	217,4	4,1	...	28,4	195,1	130,6	345,9	274,1	152,4	6	8	10-Gr 8	.750				
1140T	1050G	28 600	1650	200	242	67	89	382	0,209	1,13	384,0	348,0	406,4	184,2	254,0	5,1	...	38,1	201,2	147,3	388,9	305,8	184,2	6	10	8-Gr 8	.875				
1150T	1055G	39 800	1500	215	267	108	102	508	0,254	1,95	453,1	372,1	406,4	182,9	269,2	5,1	390,4	38,1	271,3	172,7	425,4	334,3	203,2	6	10	14-Gr 8	.875				
1160T	1060G	55 900	1350	240	293	121	115	645	0,322	2,81	501,4	404,1	457,2	198,1	304,8	6,6	436,4	25,4	278,9	186,4	457,2	366,0	228,6	6	13	14-Gr 8	.875				
1170T	1070G	74 600	1225	280	341	134	127	983	0,397	3,49	566,4	459,2	508,0	215,9	355,6	8,4	487,2	28,4	304,3	220,2	527,0	424,9	254,0	6	17	16-Gr 8	1.000				
1180T	1080G	103 000	1100	300	341	153	102	1313	0,480	3,76	629,9	510,3	660,4	238,8	393,7	8,1	554,7	31,5	321,1	248,9	590,6	450,8	279,4	6	16	16-Gr 5	1.125				
1190T	1090G	137 000	1050	335	380	153	115	1756	0,572	4,40	675,6	557,5	711,2	259,1	436,9	8,1	607,8	38,1	325,1	275,8	660,4	508,0	304,8	6	16	18-Gr 5	1.250				
1200T	1100G	186 000	900	360	405	178	127	2254	0,671	5,62	756,9	609,3	762,0	279,4	497,8	9,1	660,4	44,5	355,6	305,3	711,2	530,4	330,2	6	16	18-Gr 5	1.250				

★ Refer to Page 5 for General Information and Reference Notes.

♦ Dimension FA is for an as-cast, unmachined surface for Sizes 1080, 1090 & 1100.

Engineering Data

TABLE 13 — Recommended Commercial Keys for Bores with One Key — Millimeters & Inches

MILLIMETERS (Per ISO R773 Standard)											
Shaft Dia		Key	Shaft Dia		Key	Shaft Dia		Key	Shaft Dia		Key
Over	Through		Over	Through		Over	Through		Over	Through	
6	8	2 x 2	38	44	12 x 8	95	110	28 x 16	260	290	63 x 32
8	10	3 x 3	44	50	14 x 9	110	130	32 x 18	290	330	70 x 36
10	12	4 x 4	50	58	16 x 10	130	150	36 x 20	330	380	80 x 40
12	17	5 x 5	58	65	18 x 11	150	170	40 x 22	380	440	90 x 45
17	22	6 x 6	65	75	20 x 12	170	200	45 x 25	440	500	100 x 50
22	30	8 x 7	75	85	22 x 14	200	230	50 x 28
30	38	10 x 8	85	95	25 x 14	230	260	56 x 32

INCHES (Per ANSI B17.1 Standard)											
.438	.562	.125 x .125	1.750	2.250	.500 x .500	4.500	5.500	1.250 x 1.250	11.000	13.000	3.000 x 2.000
.562	.875	.188 x .188	2.250	2.750	.625 x .625	5.500	6.500	1.500 x 1.500	13.000	15.000	3.500 x 2.500
.875	1.250	.250 x .250	2.750	3.250	.750 x .750	6.500	7.500	1.750 x 1.500	15.000	18.000	4.000 x 3.000
1.250	1.375	.312 x .312	3.250	3.750	.875 x .875	7.500	9.000	2.000 x 1.500	18.000	20.000	5.000 x 3.500

TABLE 14 — Shaft Diameters & Ratings for 50 Hertz Metric & 60 Hertz NEMA Motors

50 HERTZ METRIC MOTORS (kW)																		
Frame Size	80	90S	90L	100L	112M	132S	132M	160M	160L	180M	180L	200M/L	225S	225M	250S	250M	280S	280M
Shaft Dia-mm	19	24	24	28	28	38	38	42	42	48	48	55	55 60	55 60	60, 65 70	60, 65 70	65, 75 80	65, 75 80
3000 RPM	0,75 1,10	1,5	2,2	3,0	4	5,5 7,5		11 15	18,5	22		30 37	45	45	55	55 75	75 90	90 110
1500 RPM	0,55 0,75	1,1	1,5	2,2 3,0	4	5,5 7,5		11 15	18,5	22		30 37	45	45	55	55 75	75 90	90 110
1000 RPM	0,37 0,55	0,75	1,1	1,5	2,2	3	4 5,5	7,5	11		15	18,5 22	30	30	37	37 45	45 50	55 75
750 RPM	0,18 0,25	0,37	0,55	0,75 1,1	1,5	2,2	3	4 5,5	7,5		11	15	18,5	22	30	30 37	37 45	45 55

NEMA 60 HERTZ MOTORS (hp)																													
Frame Size	T Frames														TS Frames														
	143	145	182	184	213	215	254	256	284	286	324	326	364	365	404	405	444	445	284	286	324	326	364	365	404	405	444	445	
Shaft Dia - Inch	.88	.88	1.13	1.13	1.38	1.38	1.63	1.63	1.88	1.88	2.13	2.13	2.38	2.38	2.88	2.88	3.38	3.38	1.63	1.63	1.88	1.88	1.88	1.88	2.13	2.13	2.38	2.38	
3600 RPM	Drip Proof	1 1/2	2-3	5	7 1/2	10	15	20	25	30	40	50	60	75	100	125	150	200	250	30	40	50	60	75	100	125	150	200	250
	Enclosed	1 1/2	2	3	5	7 1/2	10	15	20	25	30	40	50	60	75	...	100	125	150	25	30	40	50	60	75	...	100	125	150
1800 RPM	Drip Proof	1	1 1/2-2	3	5	7 1/2	10	15	20	25	30	40	50	60	75	100	125	150	200	25	30	40	50	60	75	100	125	150	200
	Enclosed	1	1 1/2-2	3	5	7 1/2	10	15	20	25	30	40	50	60	75	...	100	125	150	25	30	40	50	60	75	...	100	125	150
1200 RPM	Drip Proof & Enclosed	3/4	1	1 1/2	2	3	5	7 1/2	10	15	20	25	30	40	50	60	75	100	125	15	20	25	30	40	50	60	75	100	125
900 RPM	Drip Proof & Enclosed	1/2	3/4	1	1 1/2	2	3	5	7 1/2	10	15	20	25	30	40	50	60	75	100	10	15	20	25	30	40	50	60	75	100

OVERHANGING HUBS — Hubs may be overhung on the shafting provided there is more than one shaft diameter of hub/shaft engagement for clearance fits, or more than 3/4 times shaft diameter hub/shaft engagement for interference fits. If hub engagement is less than what is required, use a standard long hub listed in Table 23 on Page 42, or submit application details to the Factory.

Dimension L must be equal to or greater than Dimension SD for clearance fits, or greater than Dimension SD times .75 for interference fits. For Type T63, Dimension Y must be equal to or greater than Dimension X.

Example: SD = 100 mm; then L must be 100 mm or more for clearance fits or 75 mm or more for interference fits.

CAUTION: The effect of open keyways on coupling balance should always be considered.

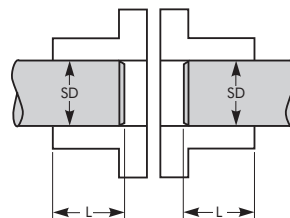

Example – Type T, Other than T63

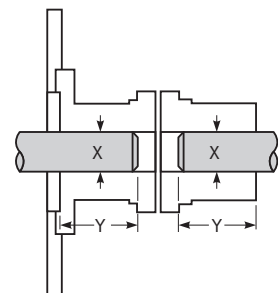

Example – Type T63

Engineering Data

TABLE 15 — Type T Hub & Flanged Hub Bore Ranges with Square & Rectangular Keys ♦

SIZE ★	Millimeters ▲				Inches														
	Min Bore	Max Bore		Min Bore ■	For One Square Key			For One Rectangular Key					For Two Square Keys			For Two Rectangular Keys			
		Std Bore Fits per Table 25 ★	Int Fit per Table 25 w/Setscrew Over Keyway		Max Bore ●	Y=X		Max Bore ●	Y=X		Max Bore ●	Y=W/2 *		Max Bore ●	Y=X		Max Bore ●	Y=X	
						W	X		W	X		W	X		W	X			
20/1020T	13	28	24	.500	1.125	.250	.125	1.187	.250	.093	1.250	.250	.062
30/1030T	13	35	30	.500	1.375	.312	.156	1.437	.375	.125	1.562	.375	.062
40/1040T	13	43	38	.500	1.625	.375	.187	1.750	.375	.125	1.750	.375	.062
50/1050T	13	50	45	.500	1.875	.500	.250	2.000	.500	.187	2.125	.500	.125
60/1060T	20	56	50	.750	2.125	.500	.250	2.250	.500	.187	2.375	.625	.125
70/1070T	20	67	60	.750	2.500	.625	.312	2.687	.625	.218	2.875	.750	.125
80/1080T	27	80	75	1.062	3.000	.750	.375	3.250	.750	.250	3.375	.875	.187
90/1090T	27	95	90	1.062	3.500	.875	.437	3.750	.875	.312	3.875	1.000	.250
100/1100T	42	110	100	1.625	4.000	1.000	.500	4.250	1.000	.375	4.500	1.000	.250
110/1110T	42	120	110	1.625	4.500	1.000	.500	4.625	1.250	.437	5.000	1.250	.250
120/1120T	61	140	120	2.375	5.000	1.250	.625	5.375	1.250	.437	5.750	1.500	.250
130/1130T	67	170	150	2.625	6.000	1.500	.750	6.500	1.500	.500	6.500	1.500	.250
140/1140T	67	200	180	2.625	7.000	1.750	.875	7.250	1.750	.750	7.750	2.000	.500
150/1150T	108	215	190	4.250	7.500	1.750	.875	8.000	2.000	.750
160/1160T	121	240	215	4.750	8.500	2.000	1.000	9.000	2.000	.750
1170T	134	280	240	5.250	9.750	2.500	1.250	10.000	2.500	.875	10.750	1.750	.875	11.000	1.750	.750
1180T	153	300	260	6.000	10.750	2.500	1.250	11.000	2.500	.875	12.000	1.750	.875	12.250	2.000	.750
1190T	153	335	290	6.000	11.750	3.000	1.500	12.000	3.000	1.000	13.000	2.000	1.000	13.250	2.000	.750
1200T	178	360	320	7.000	12.750	3.000	1.500	13.000	3.000	1.000	14.000	2.500	1.250	14.250	2.500	.875
1210T	178	390	350	7.000	13.750	3.500	1.750	14.000	3.500	1.250	15.000	2.500	1.250	15.250	2.500	.875
1220T	178	420	380	8.000	14.750	3.500	1.750	15.000	3.500	1.250	16.000	2.500	1.250	16.250	3.000	1.000
1230T	254	450	410	8.000	15.750	4.000	2.000	16.000	4.000	1.500	17.000	3.000	1.500	17.250	3.000	1.000
1240T	254	480	440	10.000	16.750	4.000	2.000	17.000	4.000	1.500	18.000	3.000	1.500	18.250	3.000	1.000
1250T	▼	▼	▼	10.000	18.000	4.000	2.000	18.500	5.000	1.750	19.250	3.500	1.750	19.750	3.500	1.250
1260T	▼	▼	▼	10.000	19.500	5.000	2.500	20.000	5.000	1.750	20.750	3.500	1.750	21.250	3.500	1.250

★ Refer to Page 5 for general information and Reference Notes.
 Metric keyways and keyway radii will be furnished per ISO/R773 (DIN 6885/1) and Js9 width tolerances unless otherwise specified. P9 and D10 width tolerance can be furnished on request. Refer to 427-140 for tolerances.
 □ Shaded areas indicate maximum bores using standard recommended keys shown on Table 13.
 ♦ Unless otherwise specified, Sizes 1020 thru 1090 will be furnished for CLEARANCE FIT with a setscrew OVER the keyway and Sizes 1100 and larger will be furnished for INTERFERENCE FIT without a setscrew. EXCEPTION: for Types T50 and T70, coupling hubs are normally furnished with an average INTERFERENCE FIT of 0,0005 mm per millimeter of shaft diameter. Clearance fit and/or hubs with setscrews are not recommended.
 * Shaft keyway depth Y equals one-half of square key W. CHECK KEY STRESSES.
 ▲ Also applies to Hub Type T61, T63, T50 pilot hub and flanged hub of T50 and T70 type couplings.
 ♣ With standard puller bolt holes per Tables 24 and 25, Page 42.
 ▼ Consult the Factory.

TABLE 16 — T31 & T35 Shaft Hub Bore Ranges with Square & Rectangular Keys ♦

SIZE ★	Millimeters				Inches										SIZE ★	
	Min Bore	Max Bore			Min Bore ■	For One Square Key			For One Rectangular Key							
		Std Bore Fits Per Table 25	Int Fit per Table 25 w/Setscrew Over Keyway	With Puller Holes Per Tables 22 or 23		Max Bore ●	Y=X		Max Bore ●	Y=X		Max Bore ●	Y=W/2 *			
							W	X		W	X		W	X		
1020T	13	35	30	35	.500	1.375	.312	.156	1.437	.375	.125	1.562	.375	.062	1020T	
1030T	13	43	38	43	.500	1.625	.375	.188	1.750	.375	.125	1030T	
1040T	13	56	50	56	.500	2.125	.500	.250	2.250	.500	.188	2.375	.625	.125	1040T	
1050T	13	67	60	67	.500	2.375	.625	.312	2.500	.625	.218	2.625	.625	.125	1050T	
1060T	20	80	75	80	.750	2.875	.750	.375	3.125	.750	.250	3.250	.750	.125	1060T	
1070T	20	85	80	85	.750	3.125	.750	.375	3.250	.750	.250	3.375	.875	.188	1070T	
1080T	27	95	90	88	1.062	3.500	.875	.438	3.750	.875	.312	3.875	1.000	.250	1080T	
1090T	27	110	100	100	1.062	4.000	1.000	.500	4.250	1.000	.375	4.500	1.000	.250	1090T	
1100T	39	130	120	120	1.500	4.750	1.250	.625	5.000	1.250	.438	5.250	1.250	.250	1100T	
1110T	51	150	140	140	2.000	5.500	1.250	.625	5.875	1.500	.500	6.250	1.500	.250	1110T	
1120T	64	170	165	160	2.500	6.250	1.500	.750	6.500	1.500	.500	6.750	1.750	.625	1120T	
1130T	77	190	180	175	3.000	6.750	1.750	.875	7.000	1.750	.750	7.250	1.750	.625	1130T	
1140T	89	210	200	200	3.500	7.500	2.000	1.000	8.000	2.000	.750	8.500	2.000	.500	1140T	
1150T	102	270	230	250	4.000	9.750	2.000	1.000	10.000	2.500	.875	1150T	
1160T	115	290	260	280	4.500	10.500	2.500	1.250	11.000	2.500	.875	1160T	
1170T	127	340	290	330	5.000	12.000	3.000	1.500	13.000	3.000	1.000	1170T	
1180T	102	340	310	340	4.000	12.000	3.000	1.500	13.000	3.000	1.000	1180T	
1190T	116	380	340	380	4.500	13.250	3.500	1.750	14.250	3.500	1.250	1190T	
1200T	127	400	365	400	5.000	14.250	3.500	1.750	15.000	3.500	1.250	1200T	

(Refer to footnotes from Table 15 above.)

Engineering Data

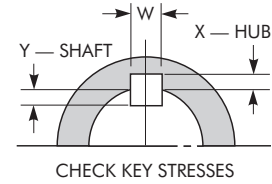

TABLE 17 — T41 Hub Bore Ranges with Square and Rectangular Keys

SIZE ★	Millimeters			Inches							
	Min Bore	Max Bore		For One Square Key				For One Rectangular Key			
		Std Bore Fits Per Table 25	Int Fit per Table 25 w/Setscrew Over Keyway	Min Bore ■	Max Bore*	Y=X		Max Bore*	W	X	Y
						W	X				
20T41	13	24 §	§	.500	1.000	.250	.125	1.125	.250	.062	.125
30T41	13	32	§	.500	1.250	.250	.125	1.375	.312	.093	.156
40T41	13	35	32	.500	1.375	.312	.156	1.625	.375	.062	.187
50T41	13	45	40	.500	1.750	.375	.187	1.875	.500	.125	.250
60T41	20	50	45	.750	1.875	.500	.250	2.125	.500	.125	.250
70T41	20	60	50	.750	2.250	.500	.250	2.500	.625	.125	.312
80T41	27	70	65	1.062	2.625	.625	.312	2.750 3.000	.625 .750	.125 .125	.312 .375
90T41	27	85	80	1.062	3.125	.750	.375	3.250 3.500	.750 .875	.125 .187	.375 .437
100T41	42	100	90	1.625	3.625	.875	.437	3.750 4.000	.875 1.000	.187 .250	.437 .500
110T41	42	110	100	1.625	4.000	1.000	.500	4.500	1.000	.250	.500
120T41	61	120	110	2.375	4.500	1.000	.500	5.000	1.250	.250	.625
130T41	67	145	135	2.625	5.250	1.250	.625	5.500 6.000	1.250 1.500	.250 .250	.625 .750
140T41	67	180	165	2.625	6.500	1.500	.750	7.250*	1.750	.500	.750
150T41	108	190	180	4.250	6.750 ♦	1.750	.875	7.000 7.500* 8.000*	1.750 1.750 2.000	.750 .500 .375	.750 .750 .750
160T41	121	225	200	4.750	7.750 ♦	2.000	1.000	8.500 9.000*	2.000 2.000	.750 .500	.750 .750
170T41	134	250	230	5.250	9.000 ♦	2.000	1.000	9.500 10.000*	2.500 2.500	.875 .500	.875 .875
180T41	153	290	260	6.000	10.250 ♦	2.500	1.250	11.000	2.500	.875	.875
190T41	153	320	285	6.000	11.000 ♦	2.500	1.250	12.000	3.000	1.000	1.000
200T41	178	340	310	7.000	12.125 ♦	3.000	1.500	13.000	3.000	1.000	1.000

★ Refer to footnotes from Table 15 and to Page 5 for General Information and Reference Notes. Unless otherwise specified, Sizes 1020 thru 1090 will be furnished for CLEARANCE Fit with a setscrew OVER the keyway and sizes 1100 and larger will be furnished for INTERFERENCE FIT without a setscrew.

♦ Maximum bore with optional square key

* A special rectangular key is required.

■ Shaded areas indicate maximum bores using standard recommended keys shown on Table 13.

§ Interference fit is not recommended.

TABLE 18 — Type G82 Hub (used on T10/G82 assemblies) Bore Ranges with Square & Rectangular Keys

SIZE ★	Millimeters				Inches							
	Min Bore	Max Bore			Min Bore ■	For One Square Key			For One Rectangular Key			
		Std Bore Fits Per Table 25	Int Fit Per Table 25 w/Setscrew Over Keyway	With Puller Holes Per Tables 22 or 23		Max Bore*	Y=X		Max Bore*	Y=X		
							W	X		W	X	
1035G	51	163	150	150	2.000	5.875	1.500	.750	6.500	1.500	.500	
1040G	64	196	167	185	2.500	6.750	1.750	.875	7.250	1.750	.750	
1045G	77	216	190	205	3.000	7.625	1.750	.875	8.125	2.000	.750	
1050G	89	235	220	228	3.500	8.750	2.000	1.000	9.000	2.000	.750	
1055G	102	266	230	250	4.000	9.750	2.000	1.000	10.000	2.500	.875	
1060G	115	290	260	280	4.500	10.500	2.500	1.250	11.000	2.500	.875	
1070G	127	340	290	330	5.000	12.000	3.000	1.500	13.000	3.000	1.000	
1080G	102	340	310	340	4.000	13.000	3.000	1.500	13.250	3.000	1.000	
1090G	115	380	340	380	4.500	14.250	3.500	1.750	15.000	3.500	1.250	
1100G	127	400	365	400	5.000	15.000	3.500	1.750	15.500	3.500	1.250	

(Refer to footnotes from Table 15.)

Engineering Data

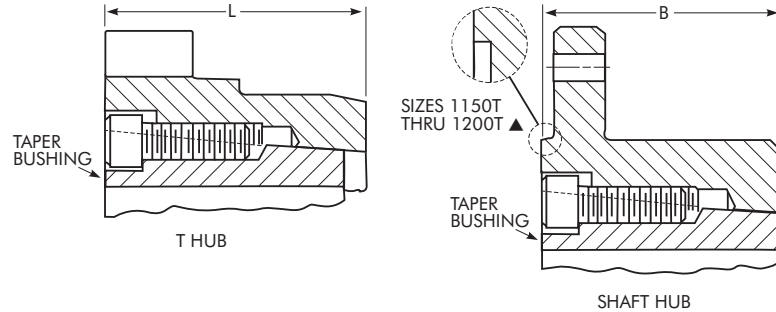

TABLE 19 — Taper-Lock® Bushings for Type T Hubs & Shaft Hubs ♦

CPLG SIZE	T Hub				Shaft Hub				
	Taper-Lock Bushing			L (mm)	Taper Lock Bushing			B (mm)	Gear Cplg Rigid Hub Size
	Bushing Number	Bore * Range (mm)	Torque Nm		Bushing Number	Bore * Range (mm)	Torque Nm		
1020T	1108	13 to 25	52	35,1	...
1030T	1108	13 to 25	147	41,1	1108	13 to 25	147	41,1	...
1040T	1108	13 to 25	147	41,1	1310	13 to 35	249	53,8	...
1050T	1215	13 to 32	407	47,8	1615	13 to 42	435	60,4	...
1060T	1615	13 to 42	486	53,8	2012	13 to 50	684	73,2	...
1070T	2012	13 to 50	808	53,8	2525	20 to 65	994	79,2	...
1080T	2525	20 to 65	1 277	66,5	2525	20 to 65	1 277	88,9	...
1090T	3030	24 to 80	2 712	79,2	3030	24 to 80	2 712	101,6	...
1100T	3030	24 to 80	2 712	88,9	3535	31 to 91	5 062	90,4	...
1110T	3535	31 to 91	5 062	91,9	4040	37 to 103	8 734	104,1	...
1120T	4040	37 to 103	8 734	111,3	4545	50 to 114	12 428	119,4	...
1130T	4545	50 to 114	12 428	117,3	5050	61 to 127	14 236	134,6	...
1140T	5050	61 to 127	14 236	130,0	5050	61 to 127	14 236	152,4	...
1150T	5050	61 to 127	14 236	182,9	6050	88 to 152	31 862	172,7 ▲	1055
1160T	5050	61 to 127	14 236	198,1	7060	100 to 177	47 002	186,4 ▲	1060
1170T	7060	100 to 177	47 002	215,9	8065	117 to 203	51 521	220,2 ▲	1070
1180T	8065	117 to 203	51 521	238,8	8065	117 to 203	51 521	248,9 ▲	1080
1190T	8065	117 to 203	51 521	259,1	10085	178 to 254	98 184	275,8 ▲	1090
1200T	10085	178 to 254	98 184	279,4	10085	178 to 254	98 184	304,8 ▲	1100

♦ Use straight bored hubs for shock load or reversing load applications or applications that require 1.75 or higher coupling service factors or refer to the Factory for selection, price and delivery of special bushings. Refer to the Factory for selection of taper-lock bushings for Type T50 and T70 couplings.

* Bushings require shaft keyways per ISO R773.

▲ For Sizes 1150T thru 1200T, dimension "B" is to the hub counterbore.

Engineering Data

TABLE 20 — WR2 Values – kg-m2
(WR2 values are based on hubs with no bore; seals, lube plugs, and gaskets are not considered)

COUPLING SIZE	Coupling Type										T70	
	T10	T20	T31		T35		T10/G82 ♦		T50			
			WR ² (Min BE)	WR ² Added Per mm of BE Over Minimum	WR ² (Min BE)	WR ² Added Per mm of BE Over Minimum	Rigid Hub Size	WR ² (Without Shaft)	WR ² Added Per mm of Length of "SD" Diameter Between Hubs	WR ² (Each Coupling)		WR ² Added Per mm of length of "SD" Diameter Between Hubs
1020T	0,0014	0,0016	0,00286	0,0000207	0,00214	0,0000207	0,00434	0,00000500	0,00434
1030T	0,0022	0,0023	0,00449	0,0000484	0,00336	0,0000484
1040T	0,0033	0,0035	0,00930	0,0000876	0,00629	0,0000876
1050T	0,0073	0,0075	0,0181	0,0000161	0,0127	0,0000161	0,0181	0,00000161	0,0181
1060T	0,012	0,012	0,0387	0,0000274	0,0253	0,0000274
1070T	0,019	0,018	0,0513	0,0000468	0,0349	0,0000468	0,0422	0,00000509	0,0420
1080T	0,045	0,043	0,116	0,0000964	0,0804	0,0000964	0,101	0,0000124	0,101
1090T	0,079	0,080	0,236	0,000187	0,157	0,000187	0,177	0,0000258	0,176
1100T	0,178	0,178	0,514	0,000313	0,346	0,000313	0,417	0,0000629	0,417
1110T	0,270	0,272	0,798	0,000523	0,534	0,000523	1035G	0,787	0,000130	0,699	0,0000916	0,697
1120T	0,514	0,472	1,56	0,000817	1,04	0,000817	1040G	1,51	0,000199	0,801	0,000162	0,800
1130T	0,990	1,05	2,51	0,00176	1,75	0,00176	1045G	2,56	0,000412	1,42	0,000266	1,42
1140T	1,85	1,88	4,35	0,00326	3,10	0,00326	1050G	4,78	0,000879	2,81	0,000348	2,80
1150T	3,49	3,29	9,00	0,00276	6,24	0,00276	1055G	8,23	0,00130	3,04	0,000559	3,04
1160T	5,82	6,03	12,8	0,00454	9,90	0,00454	1060G	12,1	0,00209	9,13	0,00130	9,13
1170T	10,4	10,4	24,8	0,00909	17,6	0,00909	1070G	23,7	0,00318	15,0	0,00130	15,0
1180T	18,3	...	39,7	0,0138	29,0	0,0138	1080G	38,3	0,00466	25,8	0,00209	25,8
1190T	26,2	...	65,0	0,0214	45,6	0,0214	1090G	62,2	0,00659	36,9	0,00318	36,9
1200T	43,6	...	93,5	0,0381	68,5	0,0381	1100G	92,7	0,00908	59,8	0,00466	59,8
1210T	75,6
1220T	113
1230T	175
1240T	339
1250T	525
1260T	712

♦ Values shown are for standard hub lengths.

Coupling Misalignment

Maximum life and minimum maintenance for the coupling and connected machinery will result if couplings are accurately aligned. Coupling life expectancy between initial alignment and maximum operating limits is a function of load, speed and lubrication. For applications requiring greater misalignment, refer application details to the Factory.

Angular misalignment is expressed in degrees and as the difference between the value of X minus Y, as illustrated.

Parallel misalignment is the distance P between shaft center lines as shown.

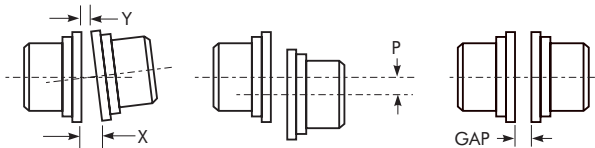

TABLE 21 — Type T Steelflex Coupling Misalignment Capacity — Millimeters ★

CPLG SIZE	Recommended Installation Maximum				Maximum Operating			Normal Gap ±10%	
	Parallel Offset – P			Angular (1/16 °) X minus Y	Parallel Offset – P ▲		Angular (1/4 °) X minus Y	All Types Except T31	Type T31
	Types T10, T20, T31, T35, T41, T63	Type T50	Type T70		Types T10, T20, T31, T35, T41, T63	Type T70			
20/1020T	0,15	0,08	0,30	...	0,25	3	5
30/1030T	0,15	0,05	0,08	0,08	0,30	0,15	0,30	3	5
40/1040T	0,15	0,08	0,30	...	0,33	3	5
50/1050T	0,20	0,05	0,10	0,10	0,41	0,20	0,41	3	5
60/1060T	0,20	0,13	0,41	...	0,46	3	5
70/1070T	0,20	0,05	0,10	0,13	0,41	0,20	0,51	3	5
80/1080T	0,20	0,05	0,10	0,15	0,41	0,20	0,61	3	5
90/1090T	0,20	0,08	0,10	0,18	0,41	0,20	0,71	3	5
100/1100T	0,25	0,08	0,13	0,20	0,51	0,25	0,84	5	6
110/1110T	0,25	0,08	0,13	0,23	0,51	0,25	0,91	5	6
120/1120T	0,28	0,08	0,15	0,25	0,56	0,28	1,02	6	10
130/1130T	0,28	0,10	0,15	0,30	0,56	0,28	1,19	6	10
140/1140T	0,28	0,10	0,15	0,33	0,56	0,28	1,35	6	10
150/1150T	0,30	0,10	0,15	0,41	0,61	0,30	1,57	6	10
160/1160T	0,30	0,13	0,15	0,46	0,61	0,30	1,78	6	10
170/1170T	0,30	0,13	0,15	0,51	0,61	0,30	2,01	6	10
180/1180T	0,38	0,13	0,20	0,56	0,76	0,38	2,26	6	10
190/1190T	0,38	0,15	0,20	0,61	0,76	0,38	2,46	6	10
200/1200T	0,38	0,15	0,20	0,69	0,76	0,38	2,72	6	10
1210T	0,46	0,74	0,91	...	3,00	13	...
1220T	0,46	0,81	0,91	...	3,28	13	...
1230T	0,46	0,89	0,97	...	3,61	13	...
1240T	0,48	0,97	0,97	...	3,91	13	...
1250T	0,51	1,07	1,02	...	4,29	13	...
1260T	0,51	1,17	1,02	...	4,65	13	...

★ Values may be combined for an installation or an operating condition.

▲ Operating offset limits between Type T50 Floating Shaft Assembly is a function of 1/4 ° and distance between shaft ends.

Engineering Data

Mill Motor and Taper Bore Dimensions — Metric Equivalent Dimensions – mm

Standardized for AISE mill motors. Also Available for use on other tapered shaft applications such as large pumps, compressors, and turbines.

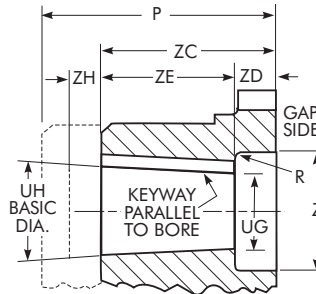

Type T Hub or T31/T35 Shaft Hubs Only.

TABLE 22 — Standard AISE AC & DC Mill Motor Coupling Selections — mm

Motor Frame Sizes			CPLG SIZE ◆	R	Z	UG	UH	Keyway	ZC	ZD	ZE	ZH ±.000 -.000
2 602	802 A, B & C	AC 1, 2 & 4	1060T	3,0	66,68	36,50	44,46	12,70 x 6,35	100,1	23,9	76,2	0,61
			1070T	3,0	66,68							
			1080T	7,9	88,90							
			1090T	7,9	88,90							
			1100T	7,9	88,90							
603 604	803 804	...	1070T	3,0	76,20	41,53	50,80	12,70 x 6,35	114,3	25,4	88,9	0,74
			1080T	9,7	101,60							
			1090T	9,7	101,60							
			1100T	9,7	101,60							
606	806	AC 8 & 12	1080T	3,0	88,90	52,91	63,50	12,70 x 6,35	130,0	28,4	101,6	0,74
			1090T	9,7	114,30							
			1100T	9,7	114,30							
			1110T	9,7	114,30							
608	808	...	1090T	3,0	111,13	64,29	76,20	19,05 x 6,35	146,0	31,8	114,3	0,74
			1100T	12,7	136,53							
			1110T	12,7	136,53							
			1120T	12,7	136,53							
610	810	AC18	1100T	3,0	127,00	70,64	82,55	19,05 x 6,35	149,4	35,1	114,3	0,86
			1110T	12,7	152,40							
			1120T	12,7	152,40							
			1130T	12,7	152,40							
612	812	AC 25 & 30	1100T	3,0	133,35	78,84	92,08	19,05 x 6,35	165,1	38,1	127,0	0,86
			1110T	3,0	133,35							
			1120T	3,0	158,75							
			1130T	3,0	158,75							
			1140T	3,0	158,75							
614	814	AC 40 & 50	1110T	3,0	149,23	94,72	107,95	25,40 x 9,53	168,1	41,1	127,0	0,86
			1120T	3,0	149,23							
			1130T	12,7	171,45							
			1140T	12,7	171,45							
616	816	...	1120T	3,0	165,10	102,92	117,48	31,75 x 9,53	184,2	44,4	139,7	0,86
			1130T	15,7	203,20							
			1140T	15,7	203,20							
618	818	...	1130T	3,0	177,80	111,13	127,00	31,75 x 12,70	185,7	33,3	152,4	0,97
			1140T	15,7	215,90		126,85		184,2		150,9	
			1150T	15,7	215,90		126,72		182,9		149,6	
620	1140T	6,4	222,25	131,37	147,98	38,10 x 19,05	204,0	44,4	159,5	0,97
			1150T	19,0	247,65		145,80		182,9		138,4	
			1160T	19,0	247,65		147,37		198,1		153,7	
622	1140T	6,4	222,25	139,57	154,51	38,10 x 19,05	204,0	60,5	143,5	0,97
			1150T	19,0	247,65		152,32		182,9		122,4	
			1160T	19,0	247,65		153,90		198,1		137,7	
			1170T	19,0	247,65		155,75		215,9		155,4	
624	1140T	6,4	222,25	153,34	168,28	38,05 x 19,05	204,0	60,5	143,5	0,97
			1150T	19,0	247,65		166,09		182,9		122,4	
			1160T	19,0	247,65		167,67		198,1		137,7	
			1170T	19,0	247,65		169,52		215,9		155,4	
			1180T	19,0	247,65		171,91		238,8		178,3	
			1190T	19,0	247,65		174,02		259,1		198,6	

◆ Coupling selections are based on coupling bore capacity and standard available hub lengths. Check coupling rating for all selections, and hub key stress for mill motor selections 620 and larger.

Engineering Data

Table 23 specifies the taper and counter bore limitations for the usual requirements. Refer applications for counter bore diameters or depths which exceed any of these limitations, and requirements for hubs longer than those listed, to the Factory with full particulars for review.

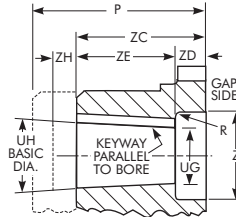

Type T Hub or T31/T35 Shaft Hubs Only. ♦

TABLE 23 — Taper & Counter Bore Limitations — Millimeters ♦

SIZE	Std Long Hub Length P Max *	R	Z Max	UG Min	UH Max	ZD Max	Keyway ▲
20/1020T	98,6	3,0	36,53	13	28	15,7	8 x 7
30/1030T	104,6	3,0	46,02	13	35	15,7	10 x 8
40/1040T	104,6	3,0	53,98	13	45	15,7	12 x 8
50/1050T	165,1	6,4	65,07	13	50	20,6	14 x 9
60/1060T	167,4	6,4	73,03	20	56	20,6	16 x 10
70/1070T	167,4	6,4	84,12	20	67	22,4	20 x 12
80/1080T	205,5	9,7	103,17	27	80	31,8	22 x 14
90/1090T	205,5	9,7	117,48	27	95	35,1	25 x 14
100/1100T	204,7	12,7	136,53	42	110	42,9	28 x 16
110/1110T	204,7	12,7	152,40	42	120	44,5	32 x 18
120/1120T	204,0	15,7	165,10	61	140	50,8	36 x 20
130/1130T	204,0	15,7	203,20	67	170	52,3	40 x 22
140/1140T	204,0	19,1	234,95	67	200	57,2	45 x 25
150/1150T	182,9	19,1	266,70	108	215	63,5	50 x 28
160/1160T	198,1	19,1	304,80	121	240	69,9	56 x 32
1170T	215,9	19,1	355,60	134	280	76,2	63 x 32

* Standard long hub length available for Type T Hubs and T31/T35 shaft hubs; consult the Factory for other hubs or longer lengths.

▲ Keyway shown is for maximum bore.

♦ Refer to the Factory for other hubs.

TABLE 24 — Type T Steelflex Coupling Puller Bolt Holes – Millimeters

SIZE	T-Hub		Shaft Hub	
	B.C.	Tap Size – 6H	B.C. ♣	Tap Size – 6H
1020T	39	M4 x 0,7 x 10	71	M10 x 1,5 x ♥
1030T	47	M4 x 0,7 x 10	79	M10 x 1,5 x ♥
1040T	54	M4 x 0,7 x 10	98	M10 x 1,5 x ♥
1050T	63	M5 x 0,8 x 10	108	M10 x 1,5 x ♥
1060T	73	M6 x 1,0 x 10	125	M10 x 1,5 x ♥
1070T	84	M6 x 1,0 x 10	133	M10 x 1,5 x ♥
1080T	100	M6 x 1,0 x 10	103	M10 x 1,5 x 13
1090T	116	M8 x 1,25 x 11	117	M10 x 1,5 x 13
1100T	133	M8 x 1,25 x 13	146	M16 x 2,0 x 21
1110T	149	M10 x 1,5 x 16	166	M16 x 2,0 x 21
1120T	168	M10 x 1,5 x 16	190	M20 x 2,5 x 24
1130T	197	M16 x 2,0 x 21	208	M20 x 2,5 x 24
1140T	236	M16 x 2,0 x 21	235	M20 x 2,5 x 24
1150T	263	M16 x 2,0 x 24		
1160T	298	M22 x 2,5 x 27		
1170T	338	M30 x 3,5 x 32		
1180T	378	M30 x 3,5 x 38		
1190T	413	M36 x 4,0 x 45		
1200T	456	M36 x 4,0 x 45		
1210T	497	M36 x 4,0 x 45		
1220T	541	M36 x 4,0 x 45		
1230T	586	M36 x 4,0 x 45		
1240T	633	M36 x 4,0 x 45		
1250T	690	M36 x 4,0 x 45		
1260T	749	M36 x 4,0 x 45		

♣ Locate puller bolt holes 90° from keyway except as noted by Footnote ▼.

♥ Drill and tap thru flange between existing holes. Relation to keyway may vary freely.

Footnotes for Table 26

♦ 1000T series information also applies to 10T series, e.g., 1020=20.

§ Also applies to hub Types T61, T63, T50 pilot hub and flanged hub of Types T50 & T70 couplings.

* Interference fit is not recommended.

TABLE 25 — Type G Gear Coupling Rigid Hub Puller Bolt Holes – Millimeters

SIZE ★	B.C. Rigid Hub	Tap Size 6H
1035G	182,37	M12 x 1,75 x 16
1040G	209,80	M16 x 2,0 x 20
1045G	233,17	M16 x 2,0 x 20
1050G	259,08	M20 x 2,5 x 22
1055G	284,48	M20 x 2,5 x 22
1060G	316,48	M20 x 2,5 x 22
1070G	368,30	M24 x 3,0 x 30
1080G	400,05	M24 x 3,0 x 30
1090G	457,20	M30 x 3,5 x 38
1100G	471,47	M36 x 4,0 x 45
1110G	520,70	M36 x 4,0 x 45

★ See Page 5 for General Information and Reference Notes.

TABLE 26 — Reduced Max Bores Interference Fit & Setscrew over Keyway — All Type T Couplings

Size ♦	T §	T41 Hub	Shaft Hub for T31 & T35
1020T	25.40	*	31.75
1030T	31.75	*	38.10
1040T	34.93	31.75	50.80
1050T	44.45	38.10	53.98
1060T	47.63	44.45	69.85
1070T	57.15	53.98	73.03
1080T	69.85	60.33	82.55
1090T	82.55	73.03	95.25
1100T	88.90	82.55	114.30
1110T	101.60	95.25	127.00
1120T	114.30	107.95	152.40
1130T	139.70	127.00	165.10
1140T	165.10	149.23	190.50
1150T	177.80	165.10	222.25
1160T	203.20	190.50	247.65
1170T	228.60	225.43	279.40
1180T	247.65	247.65	298.45
1190T	273.05	273.05	330.20
1200T	298.45	298.45	342.90

Engineering Data

**Table 28 — Recommended Bore Tolerances
Falk Steel Coupling Hubs — mm**

**Table 27 — Standard Bore Fits —
Unless Otherwise Specified, Falk
Coupling Hubs Will Be Bored
With The Following Bore Fits:**

Model	Coupling Size	Coupling Type	Bore Fit
Steelflex Grid Couplings	1020 - 1090	T10, T20, T31, T35, T41	Clearance
	1100 and Larger	All Types	Interference
	All Sizes	T50, T63, T70, T90	Interference

Shaft Diameter (ISO/R775-1969)	Bore Diameter Tolerance	Bore Diameter Tolerance		
		Nominal	Tolerance	Clearance
6 to 30	j6 / k6♦	F7	H7	M6
Over 30 to 50	k6	F7	H7	K6
Over 50 to 80	m6	F7	H7	K7
Over 80 to 100	m6	F7	H7	M7
Over 100 to 200	m6	F7	H7	P7
Over 200 to 355	m6	F7	H7	R7
Over 355 to 500	m6	F7	H7	R8

♦ Per DIN 748 — Differs from ISO/R775

TABLE 29 — Recommended Bores for Metric Shafts per ISO/R775-1969 (Millimeters)

MM	Shaft Diameter	Clearance Fit		Transitional Fit		Interference Fit	
		Hub Bore	Fit *	Hub Bore	Fit *	Hub Bore	Fit *
	j6 0,008 / - 0,003	F7 0,016 / 0,034	0.008 0,037	H7 0,000 / 0,018	- 0.008 0,021	M6 - 0,015 / - 0,064	- 0.023 - 0,001
12	12,008 / 11,997	12,016 / 12,034		12,000 / 12,018		11,985 / 11,996	
14	14,008 / 13,997	14,016 / 14,034		14,000 / 14,018		13,985 / 13,996	
16	16,008 / 15,997	16,016 / 16,034		16,000 / 16,018		15,985 / 15,996	
18	18,008 / 17,997	18,016 / 18,034		18,000 / 18,018		17,985 / 17,996	
	j6 0,009 / - 0,004	F7 0,020 / 0,041	0.011 0,045	H7 0,000 / 0,021	- 0.009 0,025	M6 - 0,017 / - 0,004	- 0.026 0,000
19	19,009 / 18,996	19,020 / 19,041		19,000 / 19,021		18,983 / 18,996	
20	20,009 / 19,996	20,020 / 20,041		20,000 / 20,021		19,983 / 19,996	
22	22,009 / 21,996	22,020 / 22,041		22,000 / 22,021		21,983 / 21,996	
24	24,009 / 23,996	24,020 / 24,041		24,000 / 24,021		23,983 / 23,996	
25	25,009 / 24,996	25,020 / 25,041		25,000 / 25,021		24,983 / 24,996	
28	28,009 / 27,996	28,020 / 28,041		28,000 / 28,021		27,983 / 27,996	
30	30,009 / 29,996	30,020 / 30,041		30,000 / 30,021		29,983 / 29,996	
>30	k6 0,018 / 0,002	F7 0,025 / 0,050	0.007 0,048	H7 0,000 / 0,025	- 0.018 0,023	K6 - 0,013 / 0,003	- 0.031 0,001
32	32,018 / 32,000	32,025 / 32,050		32,000 / 32,025		31,987 / 32,003	
35	35,018 / 35,002	35,025 / 35,050		35,000 / 35,025		34,987 / 35,003	
38	38,018 / 38,002	38,025 / 38,050		38,000 / 38,025		37,987 / 38,003	
40	40,018 / 40,002	40,025 / 40,050		40,000 / 40,025		39,987 / 40,003	
42	42,018 / 42,002	42,025 / 42,050		42,000 / 42,025		41,987 / 42,003	
45	45,018 / 45,002	45,025 / 45,050		45,000 / 45,025		44,987 / 45,003	
48	48,018 / 48,002	48,025 / 48,050		48,000 / 48,025		47,987 / 48,003	
50	50,018 / 50,002	50,025 / 50,050		50,000 / 50,025		49,987 / 50,003	
>50	m6 0,030 / 0,011	F7 0,030 / 0,060	0.000 0,049	H7 0,000 / 0,030	- 0.030 0,019	K7 - 0,021 / 0,009	- 0.051 - 0,002
55	55,030 / 55,011	55,030 / 55,060		55,000 / 55,030		54,979 / 55,009	
56	56,030 / 56,011	56,030 / 56,060		56,000 / 56,030		55,979 / 56,009	
60	60,030 / 60,011	60,030 / 60,060		60,000 / 60,030		59,979 / 60,009	
63	63,030 / 63,011	63,030 / 63,060		63,000 / 63,030		62,979 / 63,009	
65	65,030 / 65,011	65,030 / 65,060		65,000 / 65,030		64,979 / 65,009	
70	70,030 / 70,011	70,030 / 70,060		70,000 / 70,030		69,979 / 70,009	
71	71,030 / 71,011	71,030 / 71,060		71,000 / 71,030		70,979 / 71,009	
75	75,030 / 75,011	75,030 / 75,060		75,000 / 75,030		74,979 / 75,009	
80	80,030 / 80,011	80,030 / 80,060		80,000 / 80,030		79,979 / 80,009	
>80	m6 0,035 / 0,013	F7 0,036 / 0,071	0.001 0,058	H7 0,000 / 0,035	- 0.035 0,022	M7 - 0,035 / 0,000	- 0.070 - 0,013
85	85,035 / 85,013	85,036 / 85,074		85,000 / 85,035		84,965 / 85,000	
90	90,035 / 90,013	90,036 / 90,071		90,000 / 90,035		89,965 / 90,000	
95	95,035 / 95,013	95,036 / 95,071		95,000 / 95,035		94,965 / 95,000	
100	100,035 / 100,013	100,036 / 100,071		100,000 / 100,035		99,965 / 100,000	
>100	m6 0,035 / 0,013	F7 0,036 / 0,071		H7 0,000 / 0,035		P7 - 0,059 / - 0,024	- 0.094 - 0,037
110	110,035 / 110,013	110,036 / 110,071		110,000 / 110,035		109,941 / 109,976	
120	120,035 / 120,013	120,036 / 120,071		120,000 / 120,035		119,941 / 119,976	
>120	m6 0,040 / 0,015	F7 0,043 / 0,083	0.003 0,068	H7 0,000 / ,040	- 0.040 0,025	P7 - 0,068 / - 0,028	- 0.108 - 0,043
125	125,040 / 125,015	125,043 / 125,083		125,000 / 125,040		124,932 / 124,972	
130	130,040 / 130,015	130,043 / 130,083		130,000 / 130,040		129,932 / 129,972	
140	140,040 / 140,015	140,043 / 140,083		140,000 / 140,040		139,932 / 139,972	
150	150,040 / 150,015	150,043 / 150,083		150,000 / 150,040		149,932 / 149,972	
160	160,040 / 160,015	160,043 / 160,083		160,000 / 160,040		159,932 / 159,972	
170	170,040 / 170,015	170,043 / 170,083		170,000 / 170,040		169,932 / 169,972	
180	180,040 / 180,015	180,043 / 180,083		180,000 / 180,040		179,932 / 179,972	

* Positive values are clearance, negative values are interference.
© Rexnord Industries, LLC, 2003, 2007

Engineering Data

Table 29 — Recommended Bores for Metric Shafts per ISO/R775–1969 (Continued)

	Shaft Diameter	Clearance Fit		Transitional Fit		Interference Fit	
		Hub Bore	Fit *	Hub Bore	Fit *	Hub Bore	Fit *
> 180	m6	F7	0.004	H7	- 0.046	P7	0.125
MM	0,046 / 0,017	0,050 / 0,096	0,079	0,000 / 0,046	- 0,029	- 0,079 / - 0,033	- 0,050
190	190,046 / 190,017	190,050 / 190,096		190,000 / 190,046		189,921 / 189,967	
200	200,046 / 190,017	200,050 / 200,096		200,000 / 200,046		199,921 / 199,967	
> 200	m6	F7		H7		R7	- 0.155
MM	0,046 / 0,017	0,050 / 0,096		0,000 / 0,046		- 0,109 / - 0,063	- 0,080
210	210,046 / 210,017	210,050 / 210,096		210,000 / 210,046		209,891 / 209,937	
220	220,046 / 220,017	220,050 / 220,096		220,000 / 220,046		219,891 / 219,937	
225	225,046 / 225,017	225,050 / 225,096		225,000 / 225,046		224,891 / 224,937	
> 225	m6	F7		H7		R7	- 0.159
MM	0,046 / 0,017	0,050 / 0,096		0,000 / 0,046		- 0,113 / - 0,067	- 0,084
230	230,046 / 230,017	230,050 / 230,096		230,000 / 230,046		229,887 / 229,933	
240	240,046 / 240,017	240,050 / 240,096		240,000 / 240,046		239,887 / 239,933	
250	250,046 / 250,017	250,050 / 250,096		250,000 / 250,046		249,887 / 249,933	
> 250	m6	F7	0.004	H7	- 0.052	R7	- 0.178
MM	0,052 / 0,020	0,056 / 0,108	0,088	0,000 / 0,052	- 0,032	- 0,126 / - 0,074	- 0,094
260	260,052 / 260,020	260,056 / 260,108		260,000 / 260,052		259,874 / 259,926	
270	270,052 / 270,020	270,056 / 270,108		270,000 / 270,052		269,874 / 269,926	
280	280,052 / 280,020	280,056 / 280,108		280,000 / 280,052		279,874 / 279,926	
> 280	m6	F7		H7		R7	- 0.182
MM	0,052 / 0,020	0,056 / 0,108		0,000 / 0,052		- 0,130 / - 0,078	- 0,098
290	290,052 / 290,020	290,056 / 290,108		290,000 / 290,052		289,870 / 289,922	
300	300,052 / 300,020	300,056 / 300,108		300,000 / 300,052		299,870 / 299,922	
310	310,052 / 310,020	310,056 / 310,108		310,000 / 310,052		309,870 / 309,922	
315	315,052 / 315,020	315,056 / 315,108		315,000 / 315,052		314,870 / 314,922	
> 315	m6	F7	0.005	H7	- 0.057	R7	- 0.201
MM	0,057 / 0,021	0,062 / 0,119	0,098	0,000 / 0,057	- 0,036	- 0,144 / - 0,187	- 0,108
320	320,057 / 320,021	320,062 / 320,119		320,000 / 320,057		319,856 / 319,913	
330	330,057 / 330,021	330,062 / 330,119		330,000 / 330,057		329,856 / 329,913	
340	340,057 / 340,021	340,062 / 340,119		340,000 / 340,057		339,856 / 339,913	
350	350,057 / 350,021	350,062 / 350,119		350,000 / 350,057		349,856 / 349,913	
355	355,057 / 355,021	355,062 / 355,119		355,000 / 355,057		354,856 / 354,913	
> 355	m6	F7		H7		R8	- 0.260
MM	0,057 / 0,021	0,062 / 0,119		0,000 / 0,057		- 0,203 / - 0,114	- 0,135
360	360,057 / 360,021	360,062 / 360,119		360,000 / 360,057		359,797 / 359,886	
370	370,057 / 370,021	370,062 / 370,119		370,000 / 370,057		369,797 / 369,886	
380	380,057 / 380,021	380,062 / 380,119		380,000 / 380,057		379,797 / 379,886	
390	390,057 / 390,021	390,062 / 390,119		390,000 / 390,057		389,797 / 389,886	
400	400,057 / 400,021	400,062 / 400,119		400,000 / 400,057		399,797 / 399,886	
> 400	m6	F7	0.005	H7	- 0.063	R8	- 0.286
MM	0,063 / 0,023	0,068 / 0,131	0,108	0,000 / 0,063	- 0,040	- 0,223 / - 0,126	- 0,149
410	410,063 / 410,023	410,068 / 410,131		410,000 / 410,063		409,777 / 409,874	
420	420,063 / 420,023	420,068 / 420,131		420,000 / 420,063		419,777 / 419,874	
430	430,063 / 430,023	430,068 / 430,131		430,000 / 430,063		429,777 / 429,874	
440	440,063 / 440,023	440,068 / 440,131		440,000 / 440,063		439,777 / 439,874	
450	450,063 / 450,023	450,068 / 450,131		450,000 / 450,063		449,777 / 449,874	
> 450	m6	F7		H7		R8	- 0.292
MM	0,063 / 0,023	0,068 / 0,131		0,000 / 0,063		- 0,229 / - 0,132	- 0,155
460	460,063 / 460,023	460,068 / 460,131		460,000 / 460,063		459,771 / 459,868	
470	470,063 / 470,023	470,068 / 470,131		470,000 / 470,063		469,771 / 469,868	
480	480,063 / 480,023	480,068 / 480,131		480,000 / 480,063		479,771 / 479,868	
490	490,063 / 490,023	490,068 / 490,131		490,000 / 490,063		489,771 / 489,868	
500	500,063 / 500,023	500,068 / 500,131		500,000 / 500,063		499,771 / 499,868	

* Positive values are clearance; negative values are interference.

Engineering Data

TABLE 30 — Recommended Bores for Falk Steel Coupling Hubs — Inches

Shaft Dia	Clearance Fit		Interference Fit		Shaft Dia	Clearance Fit		Interference Fit		Shaft Dia	Clearance Fit		Interference Fit		Shaft Dia	Interference Fit	
	Hub Bore	Clearance	Hub Bore	Interference		Hub Bore	Clearance	Hub Bore	Interference		Hub Bore	Clearance	Hub Bore	Interference		Hub Bore	Interference
+ .0000 - .0005	+ .0010 - .0000	.0000 .0015	+ .0005 - .0000	.0000 .0010	+ .0000 - .0010	+ .0015 - .0000	.0000 .0025	+ .0010 - .0000	.0000 .0020	+ .0000 - .0010	+ .0015 - .0000	.0000 .0025	+ .0015 - .0000	.0010 .0035	+ .0000 - .0010	+ .0015 - .0000	.0015 .0040
.5000	.5000		.4990		2.2500	2.2500		2.2480		4.0625	4.0625		4.0590		6.7500	6.7460	
.5625	.5625		.5615		2.3125	2.3125		2.3105		4.1250	4.1250		4.1215		7.0000	6.9960	
.6250	.6250		.6240		2.3750	2.3750		2.3730		4.1875	4.1875		4.1840		+ .0000	+ .0020	.0020
.6875	.6875		.6865		2.4375	2.4375		2.4355		4.2500	4.2500		4.2465		- .0010	- .0000	.0050
.7500	.7500		.7490		2.5000	2.5000		2.4980		4.3125	4.3125		4.3090		7.2500	7.2450	
.8125	.8125		.8115		2.5625	2.5625		2.5605		4.3750	4.3750		4.3715		7.5000	7.4950	
.8750	.8750		.8740		2.6250	2.6250		2.6230		4.4375	4.4375		4.4340		7.7500	7.7450	
.9375	.9375		.9365		2.6875	2.6875		2.6855		4.5000	4.5000		4.4965		8.0000	7.9950	
1.0000	1.0000		.9990		2.7500	2.7500		2.7480		4.5625	4.5625		4.5590		8.2500	8.2445	
1.0625	1.0625		1.0615		2.8125	2.8125		2.8105		4.6250	4.6250		4.6215		8.5000	8.4945	
1.1250	1.1250		1.1240		2.8750	2.8750		2.8730		4.6875	4.6875		4.6840		8.7500	8.7445	
1.1875	1.1875		1.1865		2.9375	2.9375		2.9355		4.7500	4.7500		4.7465		9.0000	8.9945	
1.2500	1.2500		1.2490		3.0000	3.0000		2.9980		4.8125	4.8125		4.8090		9.2500	9.2440	
1.3125	1.3125		1.3115		+ .0000	+ .0015	.0000	+ .0010	.0005	4.8750	4.8750		4.8715		9.5000	9.4940	
1.3750	1.3750		1.3740		- .0010	- .0000	.0025	- .0000	.0025	4.9375	4.9375		4.9340		9.7500	9.7440	
1.4375	1.4375		1.4365		3.0625	3.0625		3.0600		5.0000	5.0000		4.9965		10.0000	9.9940	
1.5000	1.5000		1.4990		3.1250	3.1250		3.1225		5.0625	5.0625		5.0585		10.2500	10.2435	
+ .0000	+ .0010	.0000	+ .0005	.0000	3.1875	3.1875		3.1850		5.1250	5.1250		5.1210		10.5000	10.4935	
- .0010	- .0000	.0020	- .0000	.0015	3.2500	3.2500		3.2475		5.1875	5.1875		5.1835		10.7500	10.7435	
1.5625	1.5625		1.5610		3.3125	3.3125		3.3100		5.2500	5.2500		5.2460		11.0000	10.9935	
1.6250	1.6250		1.6235		3.3750	3.3750		3.3725		5.3125	5.3125		5.3085		11.2500	11.2430	
1.6875	1.6875		1.6860		3.4375	3.4375		3.4350		5.3750	5.3750		5.3710		11.5000	11.4930	
1.7500	1.7500		1.7485		3.5000	3.5000		3.4975		5.4375	5.4375		5.4335		11.7500	11.7430	
1.8125	1.8125		1.8110		3.5625	3.5625		3.5600		5.5000	5.5000		5.4960		12.0000	11.9930	
1.8750	1.8750		1.8735		3.6250	3.6250		3.6225		5.5625	5.5625		5.5585		12.5000	12.4925	
1.9375	1.9375		1.9360		3.6875	3.6875		3.6850		5.6250	5.6250		5.6210		13.0000	12.9925	
2.0000	2.0000		1.9985		3.7500	3.7500		3.7475		5.6875	5.6875		5.6835		13.5000	13.4920	
+ .0000	+ .0015	.0000	+ .0005	.0000	3.8125	3.8125		3.8100		5.7500	5.7500		5.7460		14.0000	13.9920	
- .0010	- .0000	.0025	- .0000	.0015	3.8750	3.8750		3.8725		5.8125	5.8125		5.8085		14.5000	14.4915	
2.0625	2.0625		2.0610		3.9375	3.9375		3.9350		5.8750	5.8750		5.8710		15.0000	14.9915	
2.1250	2.1250		2.1235		4.0000	4.0000		3.9975		5.9375	5.9375		5.9335		+ .000	+ .0025	.0055
2.1875	2.1875		2.1860							6.0000	6.0000		5.9960		- .001	- .0000	.0090
										6.2500	6.2500		6.2460		15.5000	15.4910	
										6.5000	6.5000		6.4960		16.0000	15.9910	
															16.5000	16.4905	
															17.0000	16.9905	
															17.5000	17.4895	
															18.0000	17.9895	
															18.5000	18.4890	
															19.0000	18.9890	
															19.5000	19.4880	
															20.0000	19.9880	

♦ For shaft diameters larger than 20.000, use an average interference fit of .0005" per inch of shaft diameter with the following bore tolerances:
 +.003, -.000 for over 20 to 30 dia. incl.
 +.004, -.000 for over 30 to 40 dia. incl.
 Tolerances and fits comply with, or are within, AGMA 9002-A86 standard (class 1 clearance fit).

THIS PAGE INTENTIONALLY LEFT BLANK